



PHILIPP Hole Anchor System

Installation Instruction



Transport and Mounting Systems for Precast Units

- ▲ **Technical department** – our staff would be happy to support you during your design process with suggestions for installation and of our transport and mounting systems for precast units.
- ▲ **Special constructions** – individual for your special application.
- ▲ **Practical tests in plant** – we ensure that our concepts are customized.
- ▲ **Test reports** – for documentation and your safety.
- ▲ **Service** – our engineers would be happy to train your technicians and staff at plant, consult during installation of precast units and help to optimize the production process.
- ▲ **High application safety of our products** – close cooperation with federal institute for material testing and – where required – German approvals of our products.
- ▲ **Software solutions** – design software for our sandwich anchor system.

▲ **Technical Department:**

Phone: +49 (0) 6021 / 40 27-318
Fax: +49 (0) 6021 / 40 27-329
Email: technik@philipp-gruppe.de

▲ **Sales Department:**

Phone: +49 (0) 6021 / 40 27-300
Fax: +49 (0) 6021 / 40 27-440
Email: export@philipp-gruppe.de



Contents

1. General Advice	Page	4
2. Determination of Load Group Tables.....	Page	8
3. PHILIPP Transport Anchor System	Page	9
3.1 Spread Anchor PLA-SA	Page	9
3.2 Two Hole Anchor PLA-ZA	Page	15
3.3 Erection Anchor	Page	18
3.3.1 Erection Anchor - double sided PLA-AB.....	Page	18
3.3.2 Erection Anchor - one sided PLA-AE	Page	19
3.4 Plate Anchor PLA-PA.....	Page	22
3.5 Flat Foot Anchor PLA-FF	Page	23
3.6 Garage Anchor PLA-GA	Page	24
3.7 Double Ended Column Anchor PLA-DK	Page	26
3.8 Sandwich Transport Anchor PLA-SW.....	Page	28
3.9 Universal Anchor PLA-UA 1.25-12	Page	30
4. PHILIPP Ring Clutch.....	Page	32
4.1 Ring Clutch PLA-RK with clasp for manual release.....	Page	32
4.2 Ring Clutch with Wire Loop PLA-RK (for load group 1.25).....	Page	32
5. Controlling of the Lifting Attachment.....	Page	33
5.1 Locking Bolt	Page	33
5.2 Clutch Head	Page	34
5.3 Steel Shackle.....	Page	34
5.4 Loop.....	Page	34
6. Application.....	Page	35
7. Application and Misuse	Page	36
8. Recess Formers, Holding Plates and Holding Screws	Page	38
9. Accessories.....	Page	41
10. Anchor Installation.....	Page	42



1. General Advice

The **PHILIPP Hole Anchor System** is part of the **PHILIPP Transport Anchor System** and complies with the „Safety Rules for Transport Anchors and Systems for Precast Concrete Units“(German regulation, BGR 106).

On use of **PHILIPP Hole Anchor System** attention must be paid to this installation instruction as well as the general part. The using instruction of the belonging lifting device (**PHILIPP Ring Clutch**) must also be considered. The anchor may only be used in combination with the original **PHILIPP Lifting Devices**.

1.1 Description of the System

The **PHILIPP Hole Anchor System** consists of a steel component insert into the concrete (the anchor) and a lifting component (the ring clutch). The precast unit is lifted and transported by means of a ring clutch, which is locked to the anchor cast into concrete. The design and shape of the ring clutch and anchor enable the lifting of the load in almost any load direction. The ring clutch can be unlocked either manually, direct at the clutch head, or by remote release.

1.2 Load Group

The components of **PHILIPP Hole Anchor System** are classified in terms of load groups. Every load group corresponds to the permissible load of a ring clutch to which anchors of the different load rates of a load group can be connected. The anchor loads available in each load group are shown in the table below. Incorrect connection is safely prevented since the ring clutches cannot be connected to anchors of the wrong load group.

1.3 Anchors

The anchors are made of special-quality flat steel. The shape of the anchor foot is described under the corresponding anchor types. The anchor head is provided with a hole, into which the locking bolt of the ring clutch is fitted. Each anchor carries a clearly visible, stamped manufacturer’s designation, which designates the product and the system designation (PLA), the anchor type (e.g. SA), the anchor length (e.g. 13) and the anchor load (e.g. 2.0).

1.4 Ring Clutch

The ring clutch is inserted into the recess of the cast-in anchor and the locking bolt is closed by hand. The ring clutch is thus secured to the anchor in a matter of seconds. The ring clutch can now be subjected to loads in any direction: turning, rotating and tilting can all be carried out. There is no preferred direction of pull (Picture 1). To disengage, the locking bolt is simply opened to free the ring clutch. If the access is more difficult (see German safety code „accident prevention regulation“ (UVV)) ring clutches with pneumatic or manual remote-control release can be used easily.

Table1: Load Group System

Load Group Ring Clutch	Load Rate Anchor
2.5	0.7
	1.4
	2.0
5.0	3.0
	4.0
	5.0
10.0	7.5
	10.0
26.0	12.5
	14.0
	17.0
	22.0
	26.0

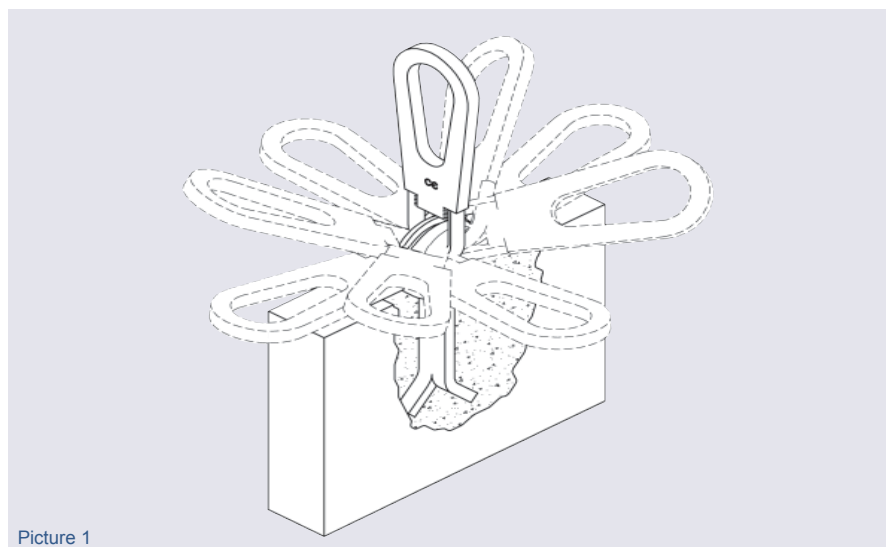

Picture 1

INSTRUCTION FOR INSTALLATION AND USE OF PHILIPP HOLE ANCHOR SYSTEM

1.5 Marking of Ring Clutches

The marking of the clutch heads is the same for all types. It consists of:

- Manufacturers quality mark "PHILIPP"
- Factory code, e.g. "81"
- Bearing capacity, e.g. "3.0-5.0tons" (load group)

Additionally, on the reverse side the position of the locking bolt is marked with "open-close".

The quality mark (P), the type designation (e.g. R1) and production date (month/year) are hard stamped on the shackle of the ring clutch (Type R1) or alternatively on the aluminium ferrules of the cable wires (Type R2). Example: "P-R1-04/05". The aluminium ferrules are marked with the DIN sign and the quality mark additionally. The ring clutches are clearly matched to the anchors by compatible design as well as by marking the anchor types and load groups. Only matching components will fit together.

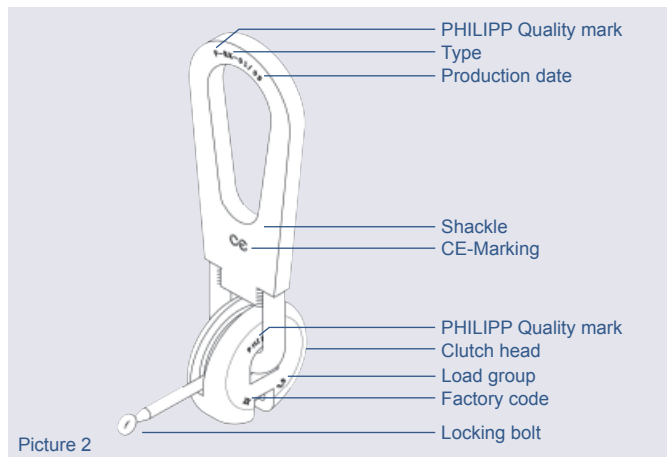

Picture 2

All lifters are designated with the CE symbol according to the machinery directive (2006/42/EG).

1.6 Marking of the Anchor

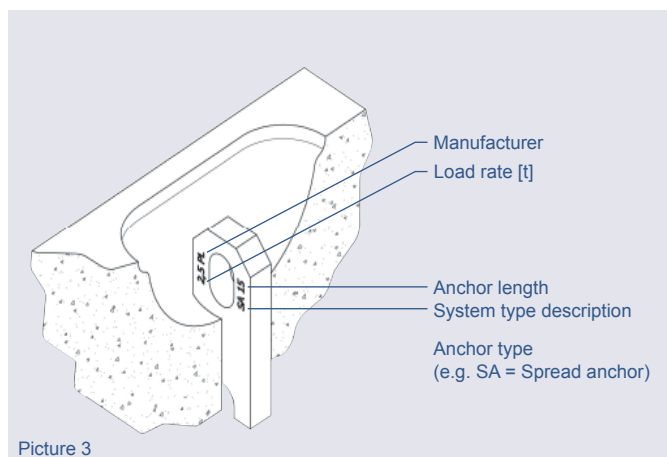

Picture 3

1.7 Illustration of the Article No.

Article No:

48 SA 025 150

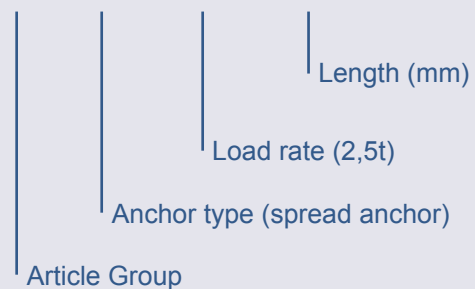

1.8 Overview of PHILIPP Hole Anchor

Spread Anchor PLA-SA

Area of Application:
Columns, beams, trusses, wall units, T-slabs

Parameters:
Unit thickness, concrete strength, reinforcement

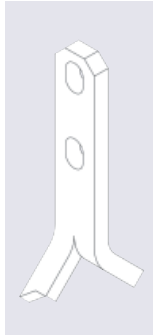

see page 10

Plate Anchor PLA-PA

Area of Application:
Very thin slabs with installation in the surface

Parameters:
Unit thickness, concrete strength, reinforcement

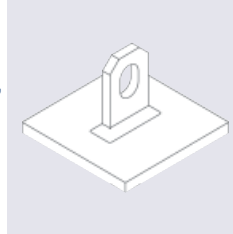

see page 22

Double Ended Column Anchor PLA-DK

Area of Application:
Columns

Parameters:
Unit thickness, concrete strength, reinforcement

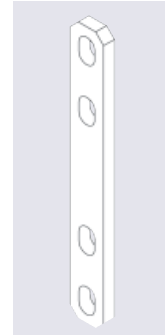

see page 26

Two Hole Anchor PLA-ZA

Area of Application:
Prestressed concrete truss, thin walled elements, low strength concrete (e.g. light-weight concrete)

Parameters:
Unit thickness, concrete strength, reinforcement
see page 15

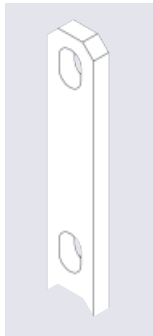

Flat Foot Anchor PLA-FF

Area of Application:
Slabs with installation in the surface

Parameters:
Unit thickness, concrete strength, reinforcement



see page 23

Sandwich Panel Anchor PLA-SW

Area of Application:
Sandwich panels

Parameters:
Unit thickness, concrete strength, reinforcement

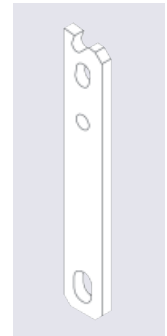

see page 28

Erection Anchor PLA-AB - double sided

Area of Application:
Thin-walled concrete units which must be tilted up

Parameters:
Unit thickness, concrete strength, reinforcement

see page 18



Garage Anchor PLA-GA

Area of Application:
Precast garages, installation in bottom plate and slabs

Parameters:
Unit thickness, concrete strength, reinforcement

see page 24

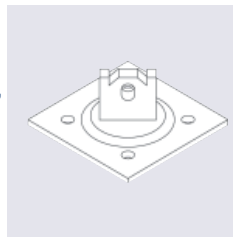

Universal Anchor PLA-UA

Area of Application:
Like PLA-FS, PLA-FZ and PLA-FA

Parameters:
Unit thickness, concrete strength, reinforcement

see page 30

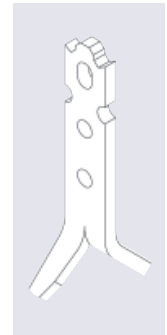

Erection Anchor PLA-AE - one sided

Area of Application:
Thin-walled concrete units which must be tilted up

Parameters:
Unit thickness, concrete strength, reinforcement

see page 9



Ring Clutch PLA-RK

With clutch for manual release

Load group
2.5 - 26.0

see page 32



Ring Clutch PLA-RK

With shackle for manual release

Load group
1.25

see page 32



INSTRUCTION FOR INSTALLATION AND USE OF PHILIPP HOLE ANCHOR SYSTEM

1.9 Classification and Properties of PHILIPP Recess Former s

Recess Former PLA-AK-A1

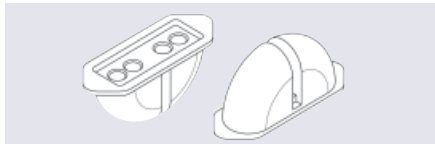

Material: plastic

Application: for all anchors except PLA-UA and PLA-GA

Installation: Holding plates PLA-AK-H1,-H2 and HM; holding screw PLA-AK-S1 or S2

Special features: high durability and good resistance to formwork treatment fluids

see page 38

Recess Former PLA-AK-A2

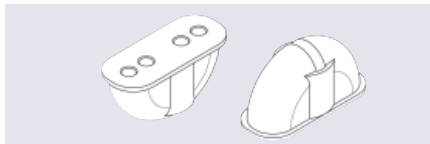

Material: rubber

Application: for anchor PLA-SA, PLA-ZA, PLA-DK, PLA-PA and PLA-FF

Installation: Holdings plates PLA-AK-H3; holding screw PLA-AK-S1 in connection with holding plate PLA-AK-H3

Special features: high durability and good resistance to formwork treatment fluids

see page 38

Recess Former PLA-AK-A3

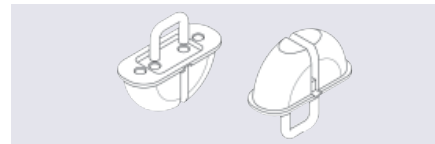

Material: rubber

Application: for anchor PLA-GA

Installation: with locking bracket

Special features: high durability and good resistance to formwork treatment fluids

see page 38

Recess Former PLA-AK-A4

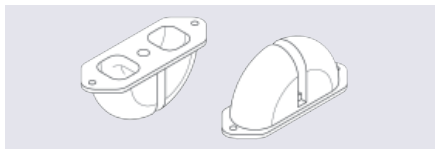

Material: plastic (hard)

Application:

for all anchors except PLA-UA and PLA-GA

Installation: Holding screw PLA-AK-S1

Special features: high durability and good resistance to formwork treatment fluids

see page 38

Recess Former PLA-AK-A5

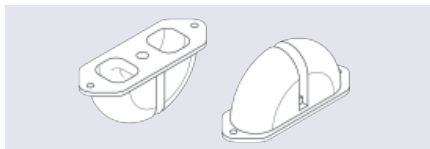

Material: Steel

Application: for all anchors except PLA-UA and PLA-GA

Installation: Holding screw PLA-AK-S1

Special features: high durability and good resistance to formwork treatment fluids

see page 38

Recess Former PLA-AK-A7

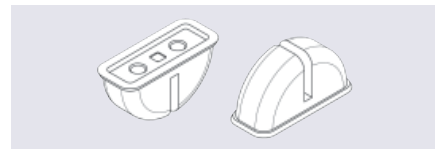

Material: plastic

Application: for universal anchor PLA-UA

Installation: Holding plates PLA-AK-H1; holding screw PLA-AK-S1

Special features: only for load group 1.25! Specially small recess. High durability and and good resistance to formwork treatment fluids

see page 38

Recess Former PLA-AK-A8

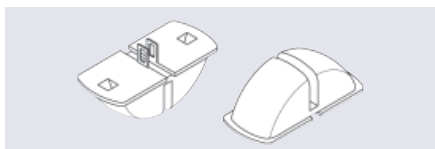

Material: plastic (hard)

Application: for all anchors except PLA-UA and PLA-GA

Installation: holding screw PLA-AK-S

Special features: high durability and good resistance to formwork treatment fluids

see page 38

Recess Former PLA-AK-A9

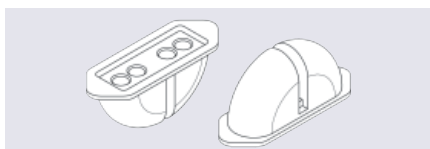

Material: plastic

Application: specially suitable for PLA-SA, PLA-ZA, PLA-FF and PLA-DK **not suitable for** PLA-AB, PLA-AE, PLA-UA, PLA-GA and PLA-SW

Installation: Holding plates PLA-AK-H1 or -H2, HM, holding screw PLA-AK-S1 or S2

Special features: A version like PLA-AK-A1 but for recesses without concrete overlap

see page 38

Recess Former PLA-AK-AM

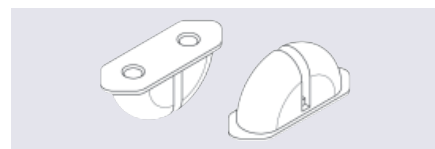

Material: plastic

Application: for all anchors except PLA-UA und PLA-GA

Installation: magnetic

Special features: high durability and good resistance to formwork treatment fluids

see page 38

2. Determination of Load Group Tables

2.1 Spread Anchor for Large Area Precast Units

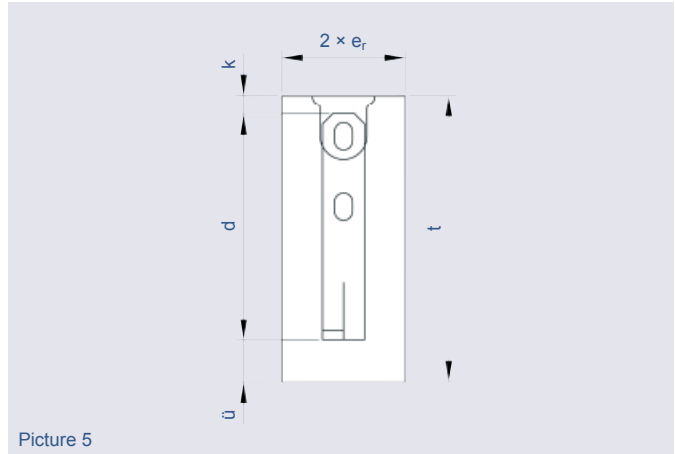
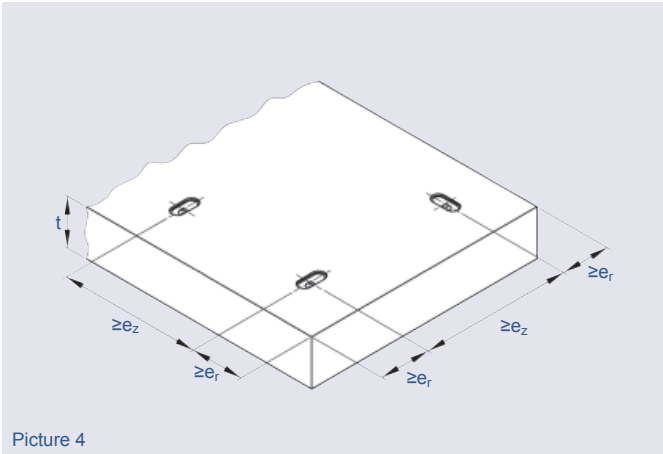

Minimum unit thickness for precast units

$$t = d + k + \ddot{u}$$

d = anchor length

k = cover of anchor head

\ddot{u} = concrete cover according to DIN 1045-1

2.2 Basic Principles of the Load Group Tables

The values for loads and edge distances in the following tables (page 10+11) have been calculated in accordance with the valid regulations, a calculation process adapted to the anchors and corresponding tests.

Table 2: Symbols for Load Directions

Load Direction	Symbol
Axial tension along the anchor axis	
Lateral tension at right angled to the flat side of the anchor	
Lateral tension parallel to the flat side of the anchor	
Diagonal tension, lateral component at right angled to the flat side of the anchor	
Diagonal tension, lateral component parallel to the flat side of the anchor	

2.3 Spread Anchor for Thin Precast Units

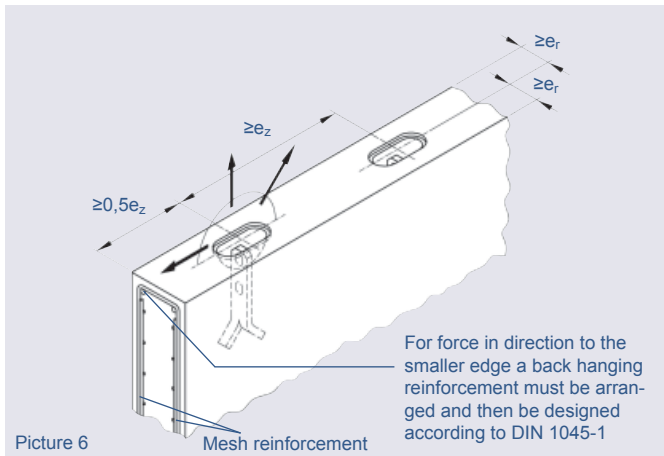

2.4 Anchor Arrangement for Thin Units

Spread, erection and two hole anchors may only be installed in thin-walled elements with the flat steel at right angles to the slab.

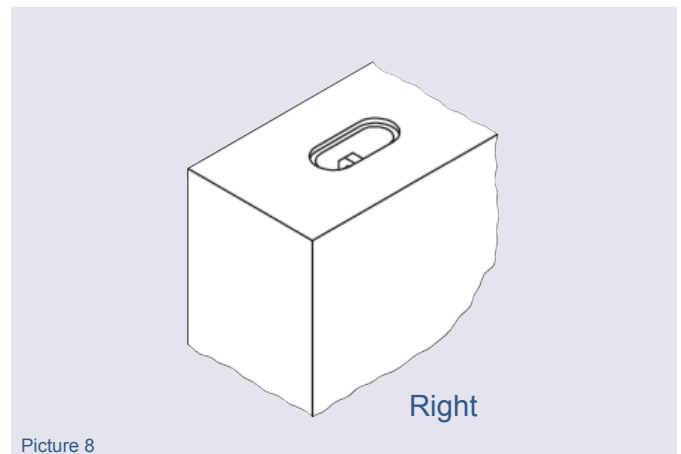
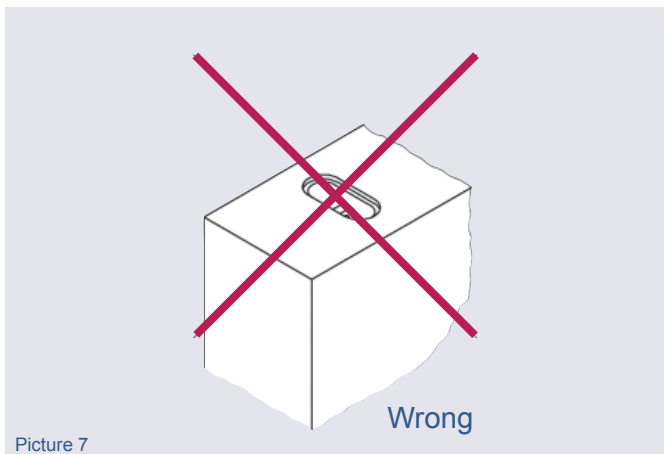

3. PHILIPP Transport Anchor System

3.1 Spread Anchor PLA-SA

3.1.1 Anchor Dimensions

The spread anchor with additional long hole is very versatile. It provides an efficient anchorage in both, thin panels and slabs. For special applications the spread anchor can also be used as two hole anchor.

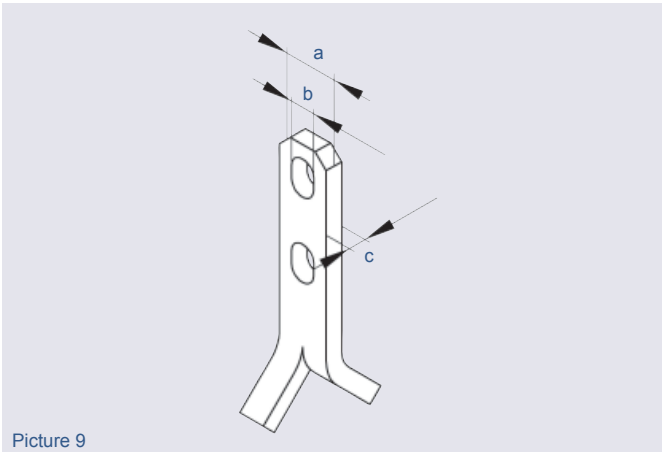

Picture 9

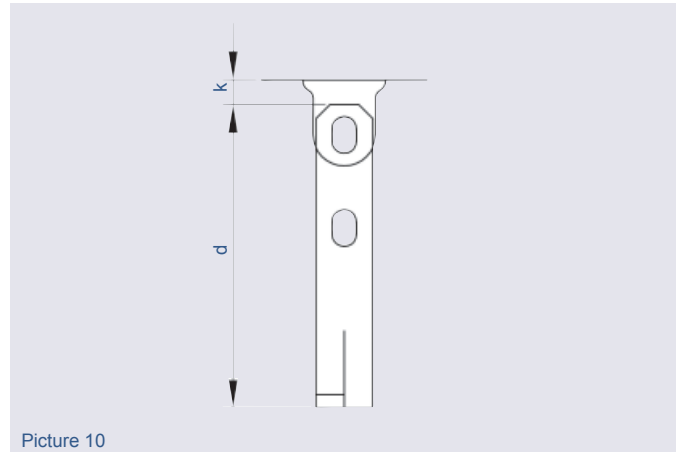

Picture 10

Table 3: Dimensions of Spread Anchor PLA-SA

Designation bright	Art.-No.	Designation hot-dip galvanized	Art.-No.	Load Group	a [mm]	b [mm]	c [mm]	d [mm]	k [mm]
PLA-SA 0.7-11	48SA007110	PLA-SA 0.7-11 FV	48SA007110FV	2.5	30	14	5	110	10
PLA-SA 1.4-11	48SA014110	PLA-SA 1.4-11 FV	48SA014110FV		30	14	6	110	
PLA-SA 1.4-16	48SA014160	PLA-SA 1.4-16 FV	48SA014160FV		30	14	6	160	
PLA-SA 2.0-13	48SA020130	PLA-SA 2.0-13 FV	48SA020130FV		30	14	8	130	
PLA-SA 2.0-16	48SA020160	PLA-SA 2.0 16 FV	48SA020160FV		30	14	8	160	
PLA-SA 2.0-21	48SA020210	PLA-SA 2.0-21 FV	48SA020210FV		30	14	8	210	
PLA-SA 2.5-15	48SA025150	PLA-SA 2.5-15 FV	48SA025150FV		30	14	10	150	
PLA-SA 2.5-20	48SA025200	PLA-SA 2.5-20 FV	48SA025200FV		30	14	10	200	
PLA-SA 2.5-25	48SA025250	PLA-SA 2.5-25 FV	48SA025250FV		30	14	10	250	
PLA-SA 3.0-16	48SA030160	PLA-SA 3.0-16 FV	48SA030160FV		5.0	40	18	10	
PLA-SA 3.0-20	48SA030200	PLA-SA 3.0-20 FV	48SA030200FV	40		18	10	200	
PLA-SA 3.0-28	48SA030280	PLA-SA 3.0-28 FV	48SA030280FV	40		18	10	280	
PLA-SA 4.0-18	48SA040180	PLA-SA 4.0-18 FV	48SA040180FV	40		18	12	180	
PLA-SA 4.0-24	48SA040240	PLA-SA 4.0-24 FV	48SA040240FV	40		18	12	240	
PLA-SA 4.0-32	48SA040320	PLA-SA 4.0-32 FV	48SA040320FV	40		18	12	320	
PLA-SA 5.0-18	48SA050180	PLA-SA 5.0-18 FV	48SA050180FV	40		18	15	180	
PLA-SA 5.0-24	48SA050240	PLA-SA 5.0-24 FV	48SA050240FV	40		18	15	240	
PLA-SA 5.0-40	48SA050400	PLA-SA 5.0-40 FV	48SA050400FV	40	18	15	400		
PLA-SA 7.5-26	48SA075260	PLA-SA 7.5-26 FV	48SA075260FV	10.0	60	26	16	260	15
PLA-SA 7.5-30	48SA075300	PLA-SA 7.5-30 FV	48SA075300FV		60	26	16	300	
PLA-SA 7.5-42	48SA075420	PLA-SA 7.5-42 FV	48SA075420FV		60	26	16	420	
PLA-SA 10.0-30	48SA100300	PLA-SA 10.0-30 FV	48SA100300FV		60	26	20	300	
PLA-SA 10.0-37	48SA100370	PLA-SA 10.0-37 FV	48SA100370FV		60	26	20	370	
PLA-SA 10.0-52	48SA100520	PLA-SA 10.0-52 FV	48SA100520FV		60	26	20	520	
PLA-SA 14.0-37	48SA140370	PLA-SA 14.0-37 FV	48SA140370FV	26.0	80	35	20	370	15
PLA-SA 14.0-46	48SA140460	PLA-SA 14.0-46 FV	48SA140460FV		80	35	20	460	
PLA-SA 22.0-50	48SA220500	PLA-SA 22.0-50 FV	48SA220500FV		90	35	28	500	
PLA-SA 22.0-62	48SA220620	PLA-SA 22.0-62 FV	48SA220620FV		90	35	28	620	

3.1.2 Load Bearing Capacities, Edge and Center Distances for Large Area or Thick-Walled Precast Units

Table 4: Load Bearing Capacities, Edge and Center Distances for Large Area or Thick-Walled Precast Units

Designation	Load Group	Anchor Length	Load Bearing Capacity	min. Beam Height	min. Edge Distance Beams e_r			min. Plate Thickness	min. Edge Distance Plates e_r			min. Center Distance		
					F_{allow}	d_1 ④	for β_w		for β_w	for β_w	for β_w		for β_w	for β_w
							$\geq 15N/mm^2$		$\geq 25N/mm^2$	$\geq 35N/mm^2$	$\geq 15N/mm^2$		$\geq 25N/mm^2$	$\geq 35N/mm^2$
d	[kN]	[mm]	$\geq 15N/mm^2$	$\geq 25N/mm^2$	$\geq 35N/mm^2$	d_2 ⑤	$\geq 15N/mm^2$	$\geq 25N/mm^2$	$\geq 35N/mm^2$	e_z				
		[mm]	[mm]	[mm]	[mm]	[mm]	[mm]	[mm]	[mm]	[mm]	[mm]			
PLA-SA 0.7-11	2.5	110	7	200	35	35	35	145	35	35	35	280		
PLA-SA 1.4-11		110	14	190	55	40	35	145	70	50	40	380		
PLA-SA 1.4-16		160	14	290	35	35	35	195	50	35	35	530		
PLA-SA 2.0-13		130	20	225	75	55	45	165	100	70	55	450		
PLA-SA 2.0-16		160	20	285	60	40	35	195	80	60	45	570		
PLA-SA 2.0-21		210	20	385	45	35	35	245	65	45	35	770		
PLA-SA 2.5-15		150	25	260	90	65	50	185	120	85	70	520		
PLA-SA 2.5-20		200	25	360	65	45	35	235	90	65	50	720		
PLA-SA 2.5-25		250	25	460	50	35	35	285	75	50	40	920		
PLA-SA 3.0-16	5.0	160	30	275	105	75	60	195	145	100	80	550		
PLA-SA 3.0-20		200	30	350	80	60	45	235	115	85	65	710		
PLA-SA 3.0-28		280	30	510	55	40	40	315	85	60	50	1025		
PLA-SA 4.0-18		180	40	310	140	100	80	215	190	135	105	610		
PLA-SA 4.0-24		240	40	425	100	70	55	275	145	100	80	850		
PLA-SA 4.0-32		320	40	590	70	50	40	355	110	75	60	1175		
PLA-SA 5.0-18		180	50	300	190	135	110	215	260	180	145	600		
PLA-SA 5.0-24		240	50	420	135	95	75	275	195	140	110	840		
PLA-SA 5.0-40		400	50	740	75	55	45	435	115	85	65	1480		
PLA-SA 7.5-26	10.0	260	75	450	210	150	120	300	300	215	175	900		
PLA-SA 7.5-30		300	75	530	180	125	100	340	265	190	150	1060		
PLA-SA 7.5-42		420	75	770	120	85	70	460	190	135	110	1540		
PLA-SA 10.0-30		300	100	515	270	190	150	340	390	275	220	1030		
PLA-SA 10.0-37		370	100	655	210	150	120	410	315	225	180	1310		
PLA-SA 10.0-52		520	100	955	140	100	80	560	225	160	130	1910		
PLA-SA 14.0-37	26.0	370	140	615	350	250	200	410	500	355	285	1230		
PLA-SA 14.0-46		460	140	795	265	190	150	500	400	285	230	1590		
PLA-SA 22.0-50		500	220	850	450	320	260	540	675	480	385	1700		
PLA-SA 22.0-62		620	220	1090	350	250	200	660	540	385	310	2180		

- Required reinforcement: minimum standard reinforcement
- ④ Straight-line interpolation may be made between minimum beam height d_1 and minimum plate thickness d_2 .
- ⑤ The concrete cover at the foot is 25mm. Smaller plate thicknesses d_2 are only possible with suitable corrosion protection.
- The upper reinforcement must be dimensioned for transport purposes.

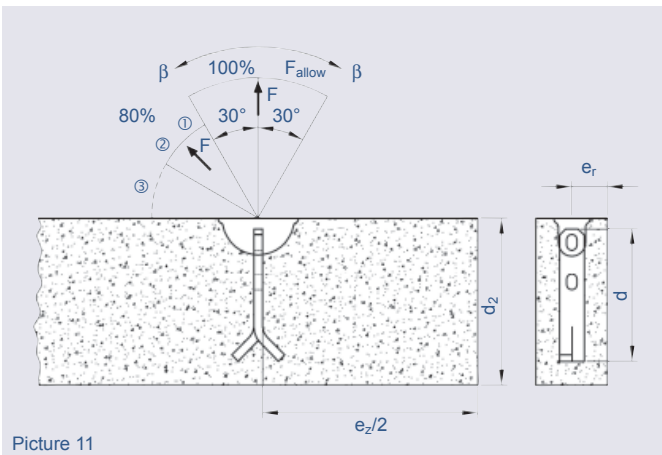

Picture 11

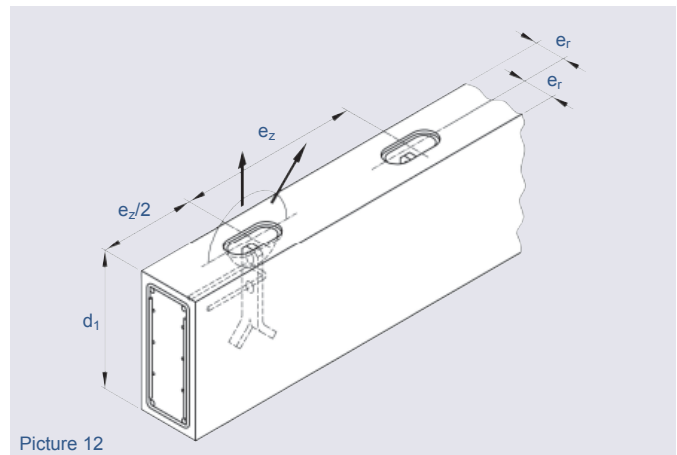

Picture 12

① **Diagonal tension with $30^\circ < \beta \leq 60^\circ$ without diagonal tension reinforcement only admissible when:**

- $\beta_w \geq 15 \text{ N/mm}^2 + 3\text{-fold min. thickness of unit}$
- $\beta_w \geq 25 \text{ N/mm}^2 + 2,5\text{-fold min. thickness of unit}$
- $\beta_w \geq 35 \text{ N/mm}^2 + 2\text{-fold min. thickness of unit}$
- (minimum thickness of unit: $e = 2 \times e_r$)

② **Where concrete strength $\beta_w \geq 23 \text{ N/mm}^2$ F_{allow} can be taken as 100%.**

③ **Angle of $\beta > 60^\circ$ due to cable spread are inadmissible!**

3.1.3 Load Bearing Capacities, Center and Edge Distances for Tilting and Turning

The horizontal tails of the tilting and turning reinforcement lay directly at the inner side of the outer layer of the standard reinforcement.

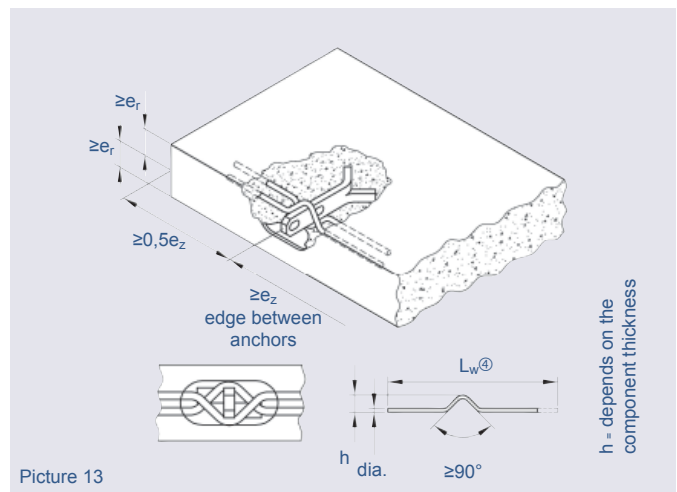

Picture 13

Table 5: Load Bearing Capacities, Center and Edge Distances for Tilting and Turning; $\beta_w \geq 15 \text{ N/mm}^2$

Designation	Load Group	Minimum Edge/ Center Distance for $\beta_w \geq 15 \text{ N/mm}^2$		Tilting/ Turning Reinforcement		Load Bearing Capacity		
		e_r [mm]	e_z [mm]	dia. [mm]	L_w ④ [mm]	Lifting [kN]	Lifting ⑤ [kN]	Tilting [kN]
PLA-SA 0.7-11	2.5	100	700	8	600	7	5.6	3.5
PLA-SA 1.4-16		100	700	10	700	14	11.2	7
PLA-SA 2.0-21		100	800	10	750	20	16.0	10
PLA-SA 2.5-25		100	875	12	800	25	20.0	12.5
PLA-SA 3.0-28	5.0	150	950	12	850	30	24.0	15
PLA-SA 4.0-32		150	1050	14	950	40	32.0	20
PLA-SA 5.0-40		150	1435	16	1000	50	40.0	25
PLA-SA 7.5-42	10.0	250	1470	20	1200	75	60.0	37.5
PLA-SA 10.0-52		300	1820	20	1500	100	80.0	50
PLA-SA 14.0-46	26.0	525	1800	25	1800	140	112.0	70
PLA-SA 26.0-62		710	2200	28	1800	220	176.0	110

- Required reinforcement: minimum standard reinforcement

④ L_w = length prior bending, bending radius according to DIN 1045-1

⑤ at a concrete strength of $\beta_w \geq 23 \text{ N/mm}^2$ 100% of the load is admissible.

3.1.4 Load Bearing Capacities, Edge and Axis Distances for Thin-Walled Precast Units

Without diagonal tension reinforcement

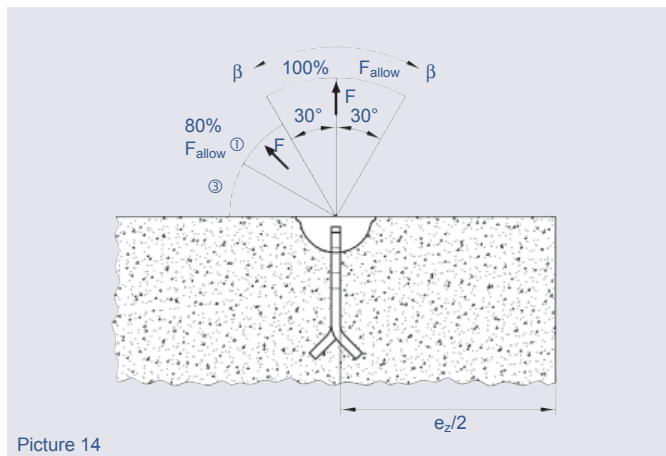

Picture 14

With diagonal tension reinforcement

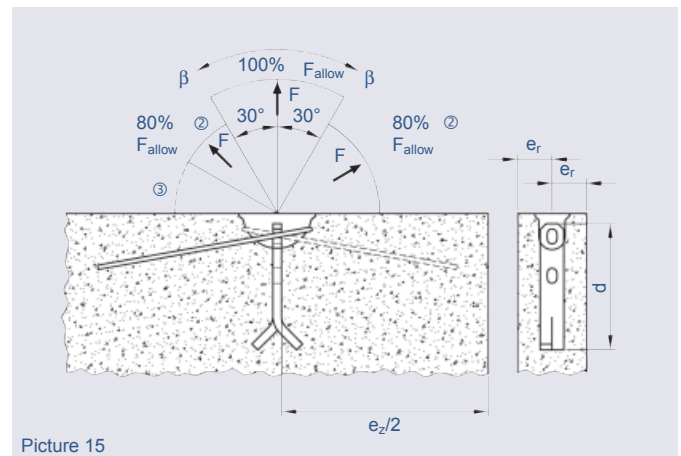

Picture 15

The diagonal tension reinforcement has to be positioned close to the recess former.

① **Diagonal tension with $30^\circ < \beta \leq 60^\circ$ without diagonal tension reinforcement only admissible when:**

- $\beta_W \geq 15 \text{ N/mm}^2 + 3\text{-fold min. thickness of unit}$
- $\beta_W \geq 25 \text{ N/mm}^2 + 2.5\text{-fold min. thickness of unit}$
- $\beta_W \geq 35 \text{ N/mm}^2 + 2\text{-fold min. thickness of unit}$
- (minimum thickness of unit: $e = 2 \times e_r$)

② **Where concrete strength $\beta_W \geq 23 \text{ N/mm}^2$ F_{allow} can be taken as 100%.**

③ **Angle of $\beta > 60^\circ$ due to cable spread are inadmissible!**

Table 6: Load Bearing Capacities and Edge Distances for Thin-Walled Precast Units

Designation	Load Group	Anchor Length d [mm]	Anchor Center Distance min e_z [mm]	Minimum Unit Thickness $2 \times e_r$			100% F_{allow} Tension ($\beta \leq 30^\circ$) [kN]	80% F_{allow} Diagonal Tension ($\beta > 30^\circ$) [kN]
				for β_W $\geq 15 \text{ N/mm}^2$ [mm]	for β_W $\geq 25 \text{ N/mm}^2$ [mm]	for β_W $\geq 35 \text{ N/mm}^2$ [mm]		
PLA-SA 0.7-11	2.5	110	330	60	60	60	7	5.6
PLA-SA 1.4-11		110	330	75	60	60	14	11.2
PLA-SA 1.4-16		160	480	75	60	60	14	11.2
PLA-SA 2.0-13		130	390	100	80	70	20	16.0
PLA-SA 2.0-16		160	480	100	80	70	20	16.0
PLA-SA 2.0-21		210	630	100	80	70	20	16.0
PLA-SA 2.5-15		150	450	120	90	80	25	20.0
PLA-SA 2.5-20	200	600	120	90	80	25	20.0	
PLA-SA 2.5-25	250	750	120	90	80	25	20.0	
PLA-SA 3.0-16	5.0	160	480	160	90	80	30	24.0
PLA-SA 3.0-20		200	600	120	90	80	30	24.0
PLA-SA 3.0-28		280	840	120	90	80	30	24.0
PLA-SA 4.0-18		180	540	210	130	100	40	32.0
PLA-SA 4.0-24		240	720	150	115	100	40	32.0
PLA-SA 4.0-32		320	960	150	115	100	40	32.0
PLA-SA 5.0-18		180	540	350	210	150	50	40.0
PLA-SA 5.0-24		240	720	180	140	120	50	40.0
PLA-SA 5.0-40	400	1200	180	140	120	50	40.0	

Continuation Table 6: Load Bearing Capacities and Edge Distances for Thin-Walled Precast Units

Designation	Load Group	Anchor Length	Anchor Center Distance	Minimum Unit Thickness $2 \times e_r$			100% F_{allow}	80% F_{allow}
				for β_w		for β_w	Tension	Diagonal Tension
				$\geq 15N/mm^2$	$\geq 25N/mm^2$	$\geq 35N/mm^2$	($\beta \leq 30^\circ$)	($\beta > 30^\circ$)
		d	min e_z	$\geq 15N/mm^2$	$\geq 25N/mm^2$	$\geq 35N/mm^2$	[kN]	[kN]
		[mm]	[mm]	[mm]	[mm]	[mm]		
PLA-SA 7.5-26	10.0	260	780	340	200	150	75	60
PLA-SA 7.5-30		300	900	240	150	130	75	60
PLA-SA 7.5-42		420	1260	195	150	130	75	60
PLA-SA 10.0-30		300	900	450	270	190	100	80
PLA-SA 10.0-37		370	1110	270	190	160	100	80
PLA-SA 10.0-52		520	1560	245	190	160	100	80
PLA-SA 14.0-37	26.0	370	1110	610	360	260	140	112
PLA-SA 14.0-46		460	1380	350	210	165	140	112
PLA-SA 22.0-50		500	1500	760	460	330	220	176
PLA-SA 22.0-62		620	1860	450	270	230	220	176

- The reinforcement data given in Table 7 on Page 13 has to be considered
- Smaller wall thicknesses are possible in the case of reverse reinforcement of the release head. However, this means reinforced concrete with a cracked tension zone.

3.1.5 Reinforcement at the Anchor Zone for Thin Walled Units

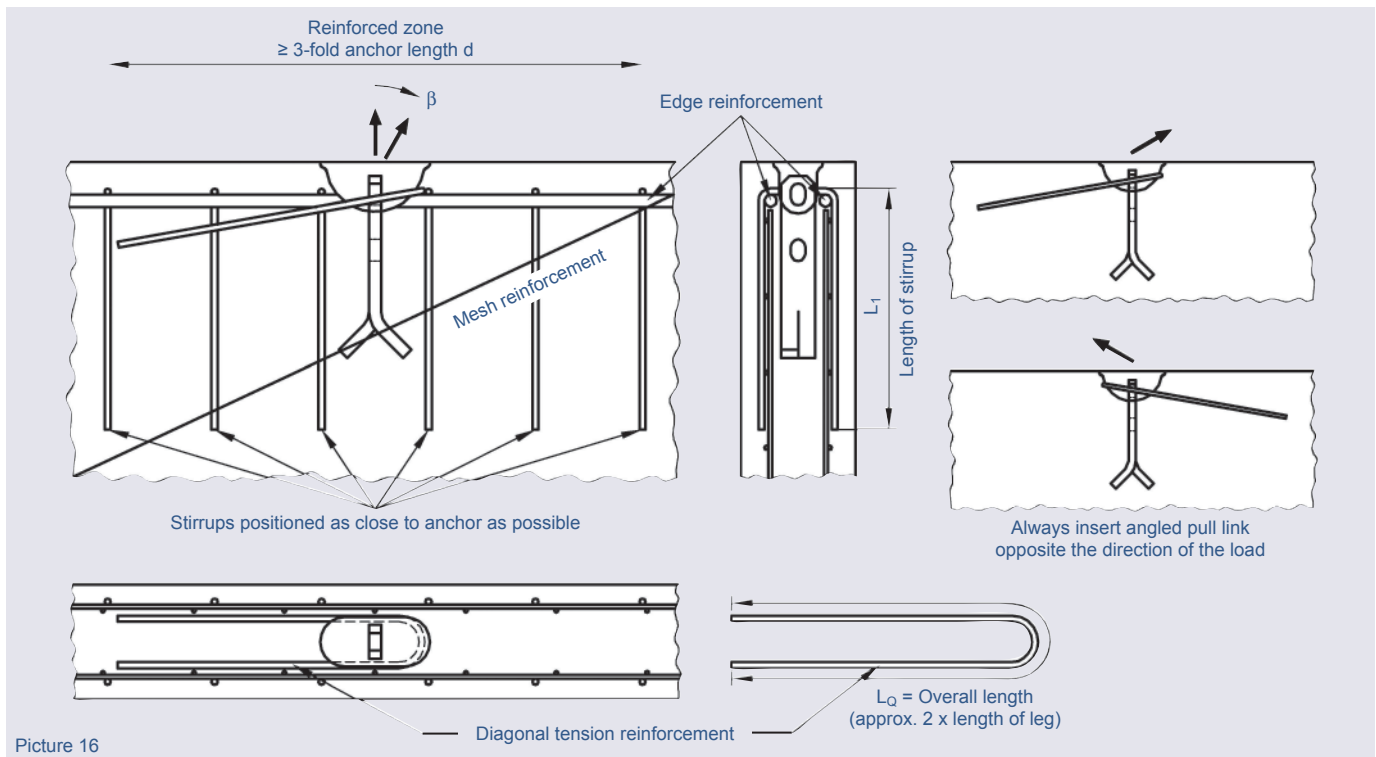

Picture 16

Table 7: Reinforcement of Thin Concrete Units; Concrete Strength $\beta_w \geq 15 \text{ N/mm}^2$

Load Group	Load Rate	Tension $\beta \leq 30^\circ$			Tension $\beta > 30^\circ$			
		Crosswise Reinforcement double sided [mm ² /m]	Stirrups BSt 500S n dia. x L ₁ [mm]	Edge Reinforcement BSt 500 S [mm]	Crosswise Reinforcement double sided [mm ² /m]	Stirrups BSt 500S n dia. x L ₁ [mm]	Edge Reinforcement BSt 500 S [mm]	Ⓛ Diagonal Reinforcement BSt 500 S n dia. x L _Q [mm]
2.5	0.7	131	constructive	constructive	131	4 dia. 6 × 300	dia. 8	dia. 6 × 450
	1.4	131	2 dia. 6 × 400	constructive	131	4 dia. 6 × 400	dia. 8	dia. 6 × 900
	2.0	131	2 dia. 6 × 500	constructive	131	4 dia. 6 × 500	dia. 8	dia. 8 × 950
	2.5	131	2 dia. 8 × 600	constructive	131	4 dia. 8 × 600	dia. 10	dia. 8 × 1200
5.0	3.0	131	2 dia. 8 × 700	constructive	131	4 dia. 8 × 700	dia. 10	dia. 10 × 1150
	4.0	131	2 dia. 8 × 800	constructive	131	4 dia. 8 × 800	dia. 12	dia. 10 × 1500
	5.0	131	2 dia. 10 × 800	constructive	131	4 dia. 10 × 800	dia. 12	dia. 12 × 1550
10.0	7.5	188	4 dia. 10 × 800	dia. 10	188	4 dia. 10 × 800	dia. 12	dia. 14 × 2000
	10.0	188	6 dia. 10 × 1000	dia. 12	188	6 dia. 10 × 1000	dia. 14	dia. 16 × 2300
26.0	14.0	257	6 dia. 10 × 1000	dia. 14	257	8 dia. 10 × 1000	dia. 14	dia. 20 × 2600
	22.0	257	8 dia. 10 × 1200	dia. 14	257	8 dia. 10 × 1200	dia. 16	dia. 28 × 3450

① **Diagonal tension reinforcement is not required if**

- at a concrete strength of $\beta_w \geq 15 \text{ N/mm}^2 + 3\text{-fold min. thickness of unit}$
- at a concrete strength of $\beta_w \geq 25 \text{ N/mm}^2 + 2.5\text{-fold min. thickness of unit}$
- at a concrete strength of $\beta_w \geq 35 \text{ N/mm}^2 + 2\text{-fold min. thickness of unit}$

3.2 Two Hole Anchor PLA-ZA

3.2.1 Anchor Dimensions

The head of the two hole anchor is identical to the head of the spread anchor. There is a second hole for additional reinforcement. The anchorage in concrete is achieved by means of a reinforcement tail. Longer anchors with additional holes can be produced on request.

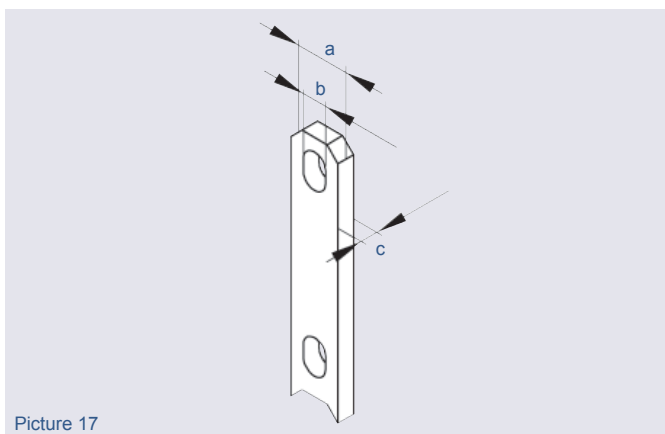

Picture 17

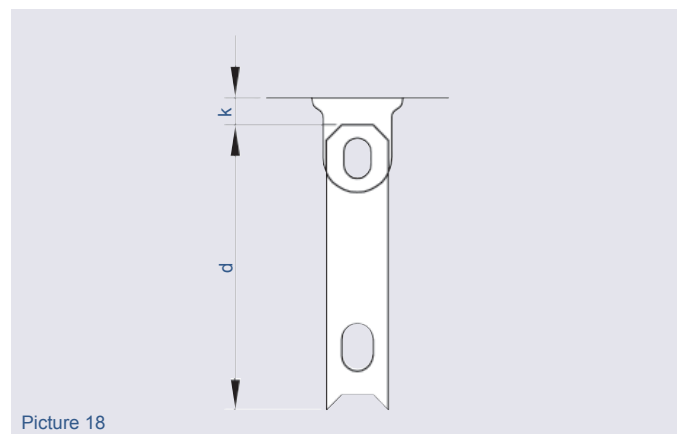

Picture 18

Table 8: Dimensions Two Hole Anchor PLA-ZA

Designation bright	Art.-No.	Designation hot-dip galvanized	Art.-No.	Load Group	a	b	c	d	k
					[mm]	[mm]	[mm]	[mm]	[mm]
PLA-ZA 1.4- 9	48ZA014090	PLA-ZA 1.4- 9 FV	48ZA014090FV	2.5	30	14	6	90	10
PLA-ZA 2.0- 9	48ZA020090	PLA-ZA 2.0- 9 FV	48ZA020090FV		30	14	8	90	
PLA-ZA 2.5- 9	48ZA025090	PLA-ZA 2.5- 9 FV	48ZA025090FV		30	14	10	90	
PLA-ZA 3.0-12	48ZA030120	PLA-ZA 3.0-12 FV	48ZA030120FV	5.0	40	18	10	120	10
PLA-ZA 4.0-12	48ZA040120	PLA-ZA 4.0-12 FV	48ZA040120FV		40	18	12	120	
PLA-ZA 5.0-12	48ZA050120	PLA-ZA 5.0-12 FV	48ZA050120FV		40	18	15	120	

Continuation Table 8: Dimensions Two Hole Anchor PLA-ZA

Designation bright	Art.-No.	Designation hot-dip galvanized	Art.-No.	Load Group	a [mm]	b [mm]	c [mm]	d [mm]	k [mm]
PLA-ZA 7.5-16	48ZA075160	PLA-ZA 7.5-16 FV	48ZA075160FV	10.0	60	26	16	160	15
PLA-ZA 10.0-17	48ZA100165	PLA-ZA 10.0-17 FV	48ZA100165FV		60	30	20	165	
PLA-ZA 14.0-24	48ZA140240	PLA-ZA 14.0-24 FV	48ZA140240FV	26.0	80	35	20	240	15
PLA-ZA 22.0-30	48ZA220300	PLA-ZA 22.0-30 FV	48ZA220300FV		90	35	28	300	
PLA-ZA 26.0-30	48ZA260300	PLA-ZA 26.0-30 FV	48ZA260300FV		120	65	30	300	

3.2.2 Load Bearing Capacities, Edge and Center Distances

Without diagonal tension reinforcement

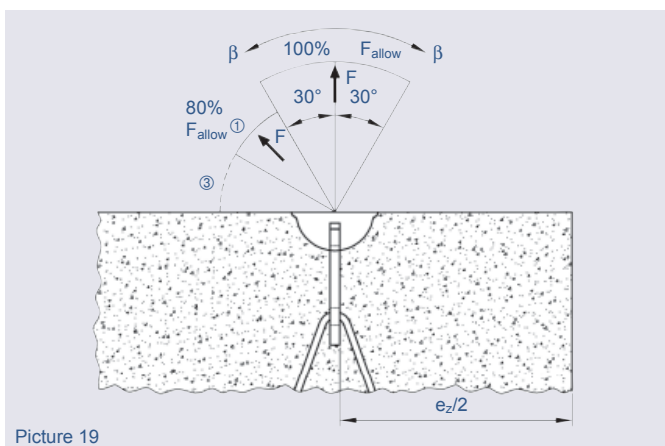

With diagonal tension reinforcement

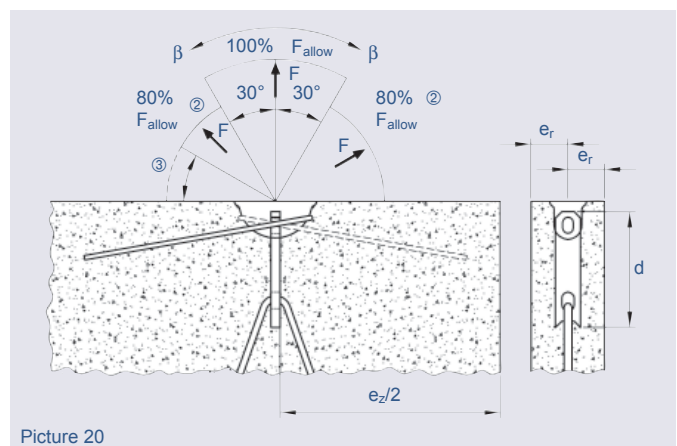

The diagonal tension reinforcement has to be positioned close to the recess former.

① **Diagonal tension with $30^\circ < \beta \leq 60^\circ$ without diagonal tension reinforcement only admissible when:**

- $\beta_w \geq 15 \text{ N/mm}^2 + 3\text{-fold min. thickness of unit}$
- $\beta_w \geq 25 \text{ N/mm}^2 + 2.5\text{-fold min. thickness of unit}$
- $\beta_w \geq 35 \text{ N/mm}^2 + 2\text{-fold min. thickness of unit}$
(minimum thickness of unit: $e = 2 \times e_r$)

② **Where concrete strength $\beta_w \geq 23 \text{ N/mm}^2$ F_{allow} can be taken as 100%.**

③ **Angle of $\beta > 60^\circ$ due to cable spread are inadmissible!**

Table 9: Load Bearing Capacities, Edge and Axis Distances PLA-ZA, Concrete Strength $\beta_w=15\text{N/mm}^2$

Designation	Load Group	Anchor Length d	Anchor Center Distance min e_z	min. Unit Thickness $2 \times e_r$	100% F_{allow} Tension $\beta \leq 30^\circ$	80% F_{allow} Diagonal Tension $\beta > 30^\circ$
		[mm]	[mm]	[mm]	[kN]	[kN]
PLA-ZA 1.4-9	2.5	90	500	80	14	11.2
PLA-ZA 2.0-9		90	600	90	20	16.0
PLA-ZA 2.5-9		90	600	100	25	20.0
PLA-ZA 3.0-12	5.0	120	650	100	30	24.0
PLA-ZA 4.0-12		120	700	110	40	32.0
PLA-ZA 5.0-12		120	750	120	50	40.0
PLA-ZA 7.5-16	10.0	160	1200	130	75	60.0
PLA-ZA 10.0-17		165	1200	140	100	80.0
PLA-ZA 14.0-24	26.0	240	1500	160	140	112.0
PLA-ZA 22.0-30		300	1500	180	220	176.0
PLA-ZA 26.0-30		300	1500	200	260	208.0

The reinforcement data of the Tables 10 and 15 have to be taken into account.

3.2.3 Reinforcement in the Anchor Zone

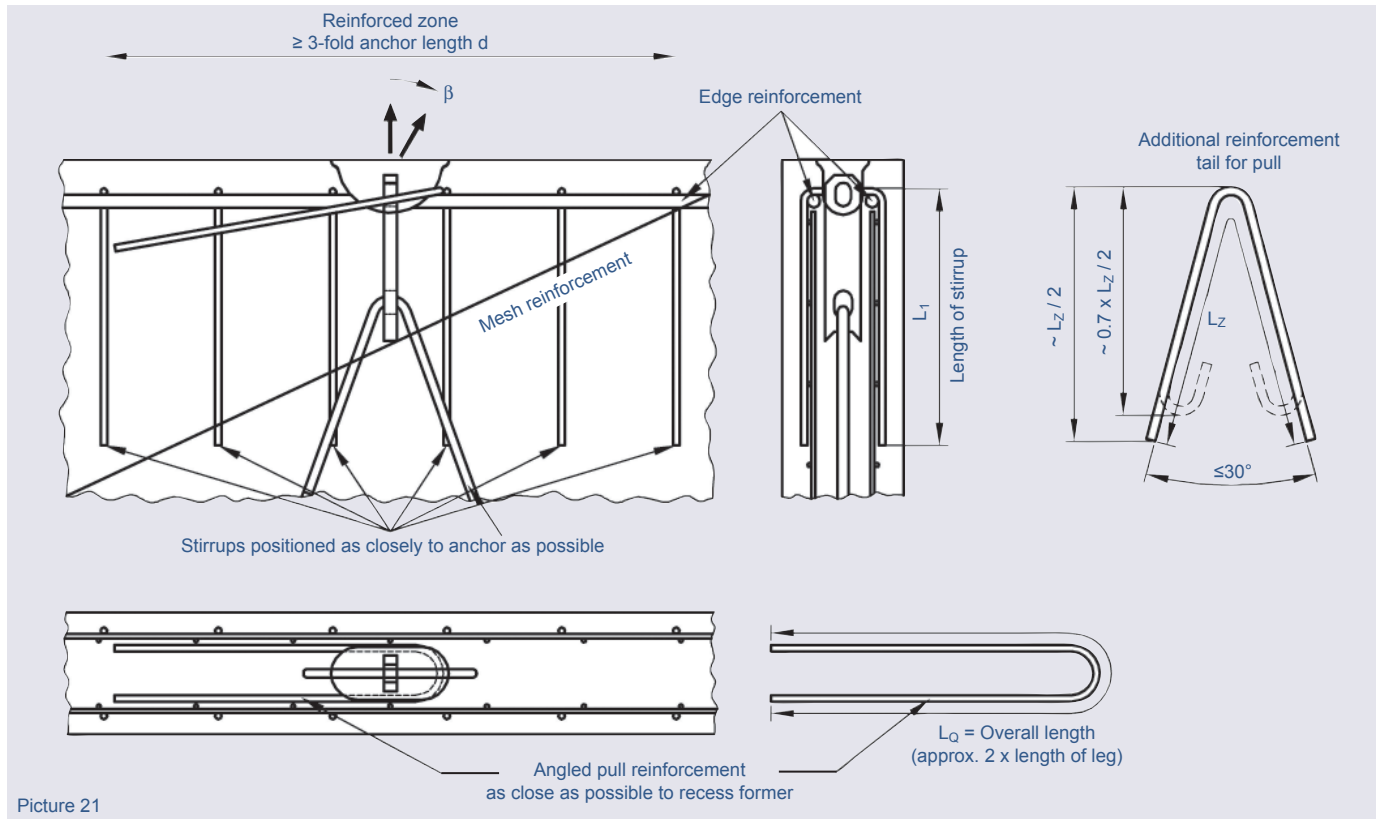

Picture 21

Table 10: Reinforcement, Concrete Strength $\beta_w \geq 15 \text{ N/mm}^2$, Tension $\beta \leq 30^\circ$

Designation	Load Group	Tension $\beta \leq 30^\circ$			
		Crosswise Reinforcement double sided	Stirrups BSt 500 S n dia. $\times L_1$	Edge Reinforcement 500 S	② Additional Reinforcement BSt 500 S n dia. $\times L_1$ double sided
		[mm ² /m]	[mm]	[mm]	
PLA-ZA 1.4-9	2.5	131	2 dia. 6 \times 400	constructive	1 dia. 10 \times 650
PLA-ZA 2.0-9		131	2 dia. 6 \times 500	constructive	1 dia. 12 \times 800
PLA-ZA 2.5-9		131	2 dia. 8 \times 600	constructive	1 dia. 12 \times 1000
PLA-ZA 3.0-12	5.0	131	2 dia. 8 \times 700	constructive	1 dia. 14 \times 1000
PLA-ZA 4.0-12		131	2 dia. 8 \times 700	constructive	1 dia. 16 \times 1200
PLA-ZA 5.0-12		131	2 dia. 8 \times 800	constructive	1 dia. 16 \times 1500
PLA-ZA 7.5-16	10.0	131	2 dia. 10 \times 800	dia. 10	1 dia. 20 \times 1750
PLA-ZA 10.0-17		131	4 dia. 10 \times 800	dia. 12	1 dia. 25 \times 1850
PLA-ZA 14.0-24	26.0	131	4 dia. 10 \times 1000	dia. 14	1 dia. 28 \times 2350
PLA-ZA 22.0-30		131	4 dia. 12 \times 1200	dia. 14	1 dia. 28 \times 3000
PLA-ZA 26.0-30		131	6 dia. 12 \times 1200	dia. 14	2 dia. 28 \times 3050

② for other concrete strengths the length L_z of the additional reinforcement can be reduced depending on the ratio of the allowed bond stresses ($\beta_w = 25 \text{ N/mm}^2 : \times 0.8$; $\beta_w = 35 \text{ N/mm}^2 : \times 0.65$).

At lower concrete strength or light weight concrete please contact us.

Table 11: Reinforcement, Concrete Strength $\beta_w \geq 15 \text{ N/mm}^2$; Tension $\beta > 30^\circ$

Designation	Load Group	Crosswise Reinforcement double sided	Stirrups BSt 500 S n dia. $\times L_1$	Tension $\beta > 30^\circ$ Edge Reinforcement BSt 500 S	② Additional Reinforcement BSt 500 S n dia. $\times L_1$	① Diagonal Reinforcement BSt 500 S n dia. $\times L_Q$
		[mm ² /m]	[mm]	[mm]		[mm]
PLA-ZA 1.4- 9	2.5	131	4 dia. 6 \times 400	dia. 8	1 dia. 10 \times 650	dia. 6 \times 900
PLA-ZA 2.0- 9		131	4 dia. 6 \times 500	dia. 8	1 dia. 10 \times 800	dia. 8 \times 950
PLA-ZA 2.5- 9		131	4 dia. 8 \times 600	dia. 10	1 dia. 12 \times 1000	dia. 8 \times 1200
PLA-ZA 3.0-12	5.0	131	4 dia. 8 \times 700	dia. 10	1 dia. 14 \times 1000	dia. 10 \times 1150
PLA-ZA 4.0-12		131	4 dia. 8 \times 800	dia. 12	1 dia. 16 \times 1200	dia. 10 \times 1500
PLA-ZA 5.0-12		131	4 dia. 10 \times 800	dia. 12	1 dia. 16 \times 1500	dia. 12 \times 1550
PLA-ZA 7.5-16	10.0	131	4 dia. 10 \times 800	dia. 12	1 dia. 20 \times 1750	dia. 14 \times 2000
PLA-ZA10.0-17		131	6 dia. 10 \times 1000	dia. 14	1 dia. 25 \times 1850	dia. 16 \times 2300
PLA-ZA14.0-24	26.0	131	8 dia. 10 \times 1000	dia. 14	1 dia. 28 \times 2350	dia. 20 \times 2600
PLA-ZA22.0-30		131	8 dia. 10 \times 1200	dia. 16	1 dia. 28 \times 3000	dia. 25 \times 3000
PLA-ZA26.0-30		131	8 dia. 12 \times 1200	dia. 16	2 dia. 28 \times 3050	dia. 28 \times 3450

① **Diagonal tension reinforcement is not required if**

- At a concrete strength of $\beta_w \geq 15 \text{ N/mm}^2 + 3\text{-fold min. thickness of unit}$
- At a concrete strength of $\beta_w \geq 25 \text{ N/mm}^2 + 2.5\text{-fold min. thickness of unit}$
- At a concrete strength of $\beta_w \geq 35 \text{ N/mm}^2 + 2\text{-fold min. thickness of unit}$

② for other concrete strengths the length L_z of the additional reinforcement can be reduced depending on the ratio of the allowed bond stress ($\beta_w=25\text{N/mm}^2 : \times 0.8$; $\beta_w=35\text{N/mm}^2 : \times 0.65$)

At lower concrete strength or light weight concrete please contact us.

3.3 Erection Anchor PLA-AB-double sided/ Erection Anchor PLA-AE-one sided

3.3.1 Anchor Dimensions Erection Anchor PLA-AB-double sided

The special shaped anchor head means that the pitching/turning loads are taken by the anchor and are not transferred through the concrete. This helps to prevent spalling of the concrete. The anchors are notched to assist with the placement of additional reinforcement required in the pitching/turning operation.

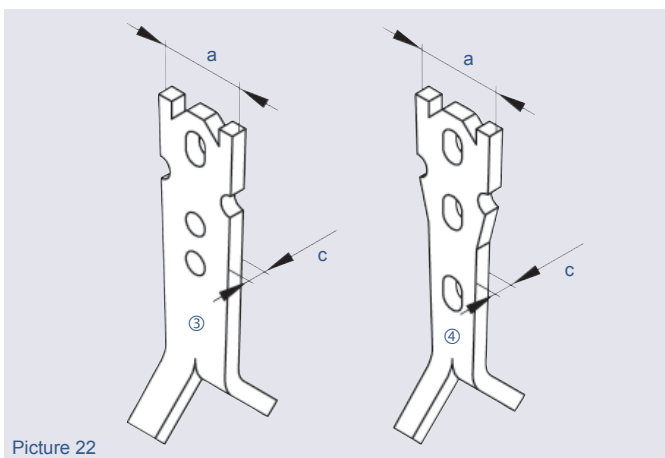

Picture 22

③ Load Rate 1.4t - 17.0t

④ Load Rate 22.0t

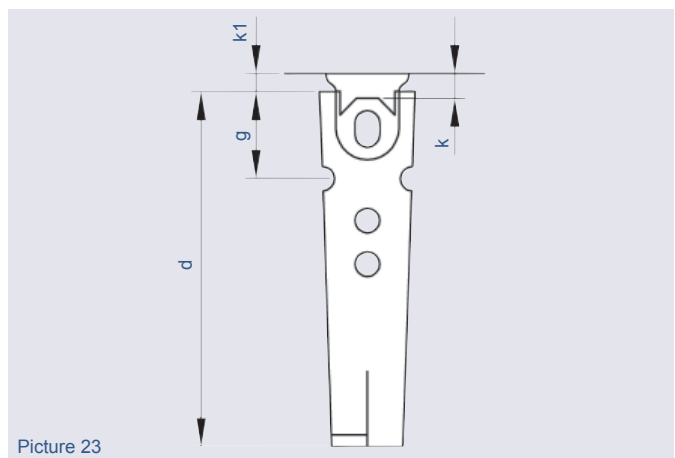

Picture 23

Tabelle 12: Dimensions Erection Anchor PLA-AB - one sided

Designation bright	Art.-No.	Designation hot-dip galvanized	Art.-No.	Load Group	a [mm]	c [mm]	d [mm]	g [mm]	k [mm]	k ₁ [mm]
PLA-AB 1.4-20	48AB0140200	PLA-AB 1.4-20 FV	48AB0140200FV	2.5	55	6	200	45	10	5
PLA-AB 2.5-23	48AB0250230	PLA-AB 2.5-23 FV	48AB0250230FV		55	10	230	45		
PLA-AB 4.0-27	48AB0400270	PLA-AB 4.0-27 FV	48AB0400270FV	5.0	70	12	270	70	10	5
PLA-AB 5.0-29	48AB0500290	PLA-AB 5.0-29 FV	48AB0500290FV		70	15	290	70		
PLA-AB 7.5-32	48AB0750320	PLA-AB 7.5-32 FV	48AB0750320FV	10.0	95	15	320	90	15	6
PLA-AB 10.0-39	48AB1000390	PLA-AB 10.0-39 FV	48AB1000390FV		95	20	390	90		
PLA-AB 12.5-50	48AB1250500	PLA-AB 12.5-50 FV	48AB1250500FV	26.0	148	20	500	90	15	9
PLA-AB 17.0-50	48AB1700500	PLA-AB 17.0-50 FV	48AB1700500FV		148	25	500	90		
PLA-AB 22.0-50	48AB2200500	PLA-AB 22.0-50 FV	48AB2200500FV		148	30	500	90		

3.3.2 Anchor Dimensions Erection Anchor PLA-AE-one sided

In contrast to the erection anchor PLA-AB, the PLA-AK-AE can only be subjected to load in one direction. It's shape makes it particularly suitable for thin components. A semi-circular notch is provided for fitting of the turning reinforcement.

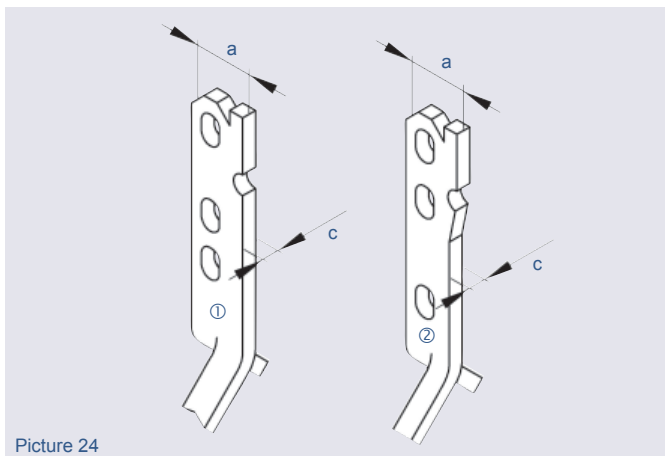

Picture 24

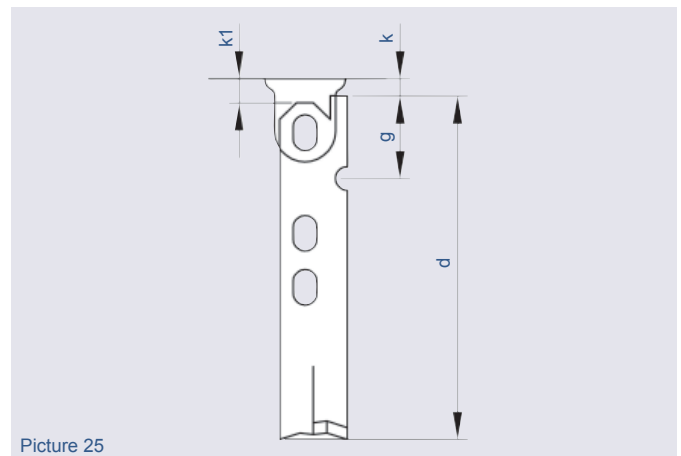

Picture 25

③ Load Rate 1.4t - 17.0t

④ Load Rate 22.0t

Tabelle 13: Dimensions Erection Anchor PLA-AE-one sided

Designation bright	Art.-No.	Designation hot-dip galvanized	Art.-No.	Load Group	a [mm]	c [mm]	d [mm]	g [mm]	k [mm]	k ₁ [mm]
PLA-AE 1.4-20	48AE0140200	PLA-AE 1.4-20 FV	48AE0140200FV	2.5	40	6	200	42.2	10	5
PLA-AE 2.5-23	48AE0250230	PLA-AE 2.5-23 FV	48AE0250230FV		40	10	230	42.5		
PLA-AE 4.0-27	48AE0400270	PLA-AE 4.0-27 FV	48AE0400270FV	5.0	55	12	270	50.5	10	5
PLA-AE 5.0-29	48AE0500290	PLA-AE 5.0-29 FV	48AE0500290FV		55	15	290	50.5		
PLA-AE 7.5-32	48AE0750320	PLA-AE 7.5-32 FV	48AE0750320FV	10.0	80	15	320	78.0	15	6
PLA-AE 10.0-39	48AE1000390	PLA-AE 10.0-39 FV	48AE1000390FV		80	20	390	78.0		
PLA-AE 12.5-50	48AE1250500	PLA-AE 12.5-50 FV	48AE1250500FV	26.0	115	20	500	88.5	15	9
PLA-AE 17.0-50	48AE1700500	PLA-AE 17.0-50 FV	48AE1700500FV		115	25	500	88.5		
PLA-AE 22.0-50	48AE2200500	PLA-AE 22.0-50 FV	48AE2200500FV		115	30	500	88.5		

3.3.3 Allowed Loads, Edge and Axis Distance

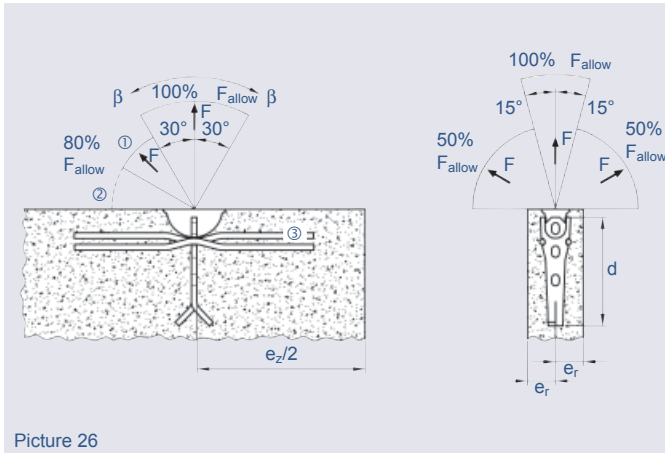

Picture 26

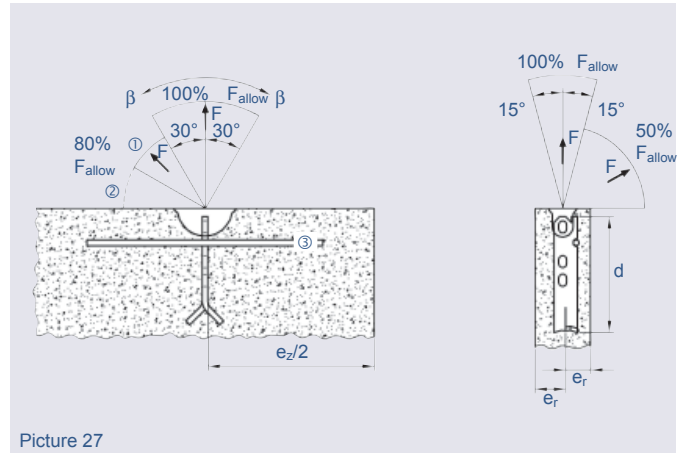

Picture 27

- ① At a concrete strength of $\beta_w \geq 23\text{N/mm}^2$ 100% of the load is admissible
- ② Angle of $\beta > 60^\circ$ due to cable spread are not allowed!
- ③ Insert the erection reinforcement in the anchor notches.

Table 14: Load Bearing Capacity, Edge and Center Distances, Concrete Strength $\beta_w \geq 15\text{N/mm}^2$

Load Group	Load Rate	Anchor Length	Anchor Center Distance		Minimum Unit Thickness ($2 \times e_r$)				Lifting Tension $(\beta \leq 30^\circ)$ $100\% F_{allow}$ [kN]	Lifting Diagonal Tension $(\beta > 30^\circ)$ $80\% F_{allow}$ [kN]	Tilting $50\% F_{allow}$ [kN]
			d [mm]	e_z [mm]	with Additional Reinforcement PLA-AE [mm] PLA-AB [mm]	without Additional Reinforcement PLA-AE [mm] PLA-AB [mm]					
2.5	1.4	200	700	90 100	90 100	14	11	7			
	2.5	230	800	120 120	120 120	25	20	13			
5.0	4.0	270	950	140 150	150 150	40	32	20			
	5.0	290	1000	140 160	180 180	50	40	25			
10.0	7.5	320	1200	160 175	200 200	75	60	38			
	10.0	390	1500	200 200	250 250	100	80	50			
26.0	12.5	500	1500	240 240	320 320	140	112	70			
	17.0	500	1500	300 300	380 380	170	136	85			
	22.0	500	1500	360 360	450 450	220	176	110			

Please consider reinforcement details on Page 21, Table 15.

3.3.4 Reinforcement in the Anchor Zone

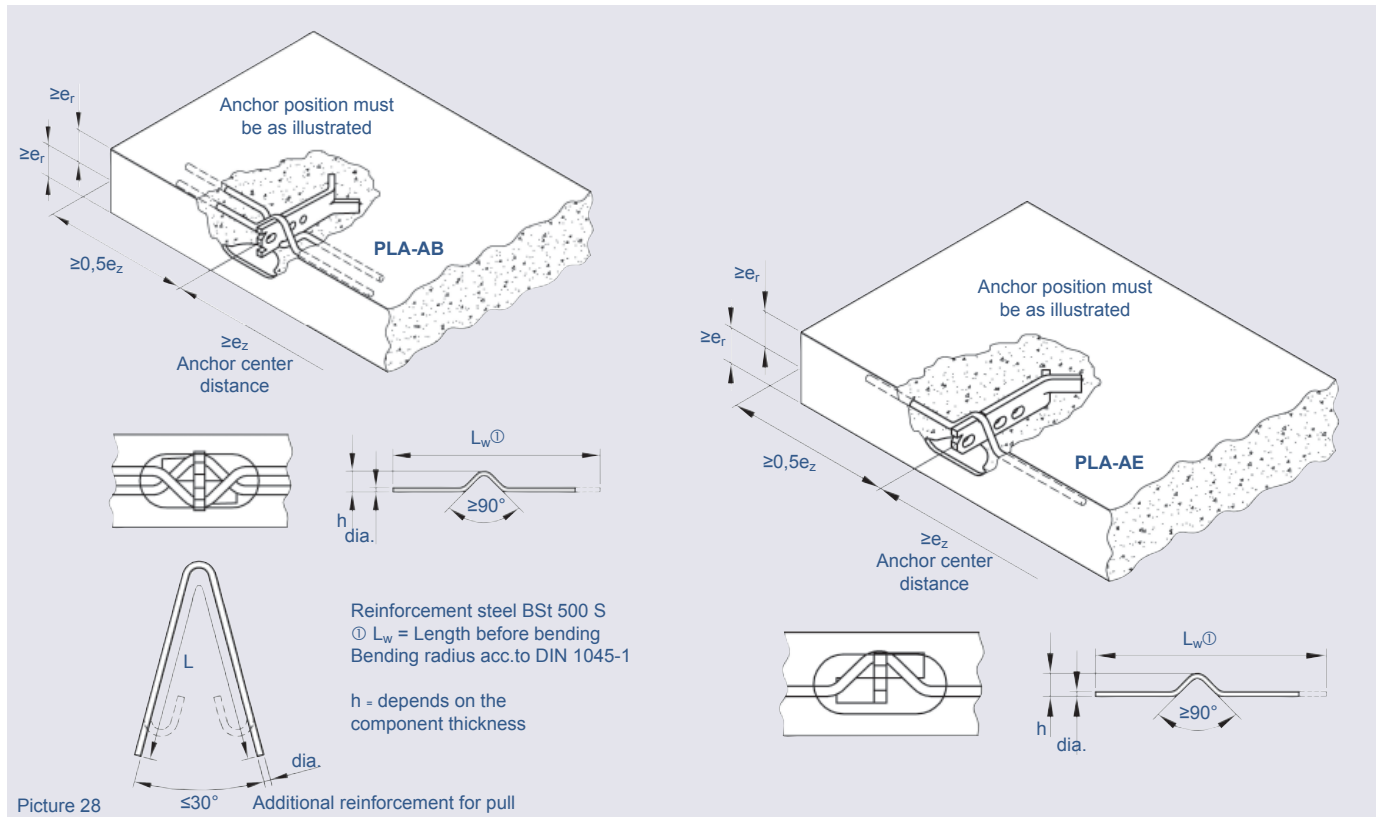

The horizontal legs of the tilting and turning reinforcement are located directly within the outermost position of the reinforced area. Tilting reinforcement on both sides also acts as angled pull reinforcement. No additional angled pull reinforcement is required.

Without additional reinforcement for tension:
Meshes, stirrups and edge reinforcement as for PLA-SA.

With additional reinforcement for tension:
Meshes, stirrups and edge reinforcement as for PLA-ZA.

Table 15: Reinforcement for Thin-Walled Concrete Units; Concrete Strength $\beta_W \geq 15\text{N/mm}^2$

Load Group	Load Rate	Tilting Reinforcement BS 500 dia. × L _w ^② [mm]	Additional Reinforcement for Tension BS 500 dia. × L
2.5	1.4	dia. 10 × 700	dia. 10 × 650
	2.5	dia. 12 × 800	dia. 12 × 1000
5.0	4.0	dia. 14 × 950	dia. 16 × 1200
	5.0	dia. 16 × 1000	dia. 16 × 1500
10.0	7.5	dia. 20 × 1200	dia. 20 × 1750
	10.0	dia. 20 × 1500	dia. 20 × 1900
26.0	12.5	dia. 25 × 1500	dia. 25 × 2200
	17.0	dia. 25 × 1800	dia. 28 × 2500
	22.0	dia. 25 × 1800	dia. 28 × 3000

② For other concrete strengths the length L_Z of the additional reinforcement can be reduced depending on the ratio of the allowed bond stresses ($\beta_W=25\text{N/mm}^2 : \times 0.8$; $\beta_W=35\text{N/mm}^2 : \times 0.65$)
For lower concrete strengths or light weight concrete please contact us.

3.4 Plate Anchor PLA-PA

3.4.1 Anchor Dimensions PLA-PA

This anchor mainly is used for thin slabs. Additional reinforcement is essential.

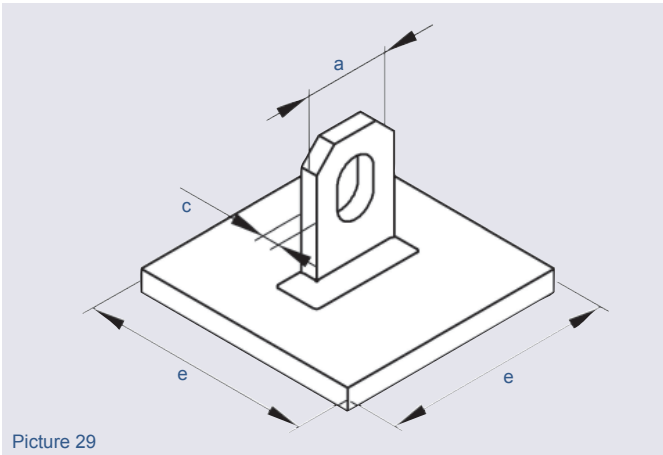

Picture 29

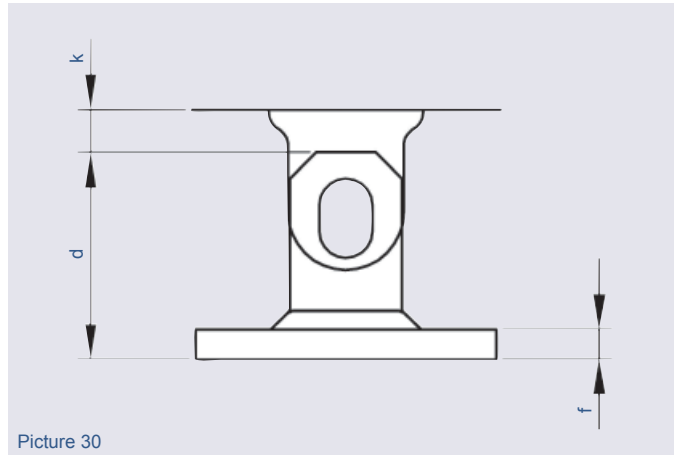

Picture 30

Table 16: Dimensions Plate Anchor PLA-PA

Designation bright	Art.-No.	Designation hot-dip galvanized	Art.-No.	Load Group	a [mm]	c [mm]	d [mm]	e [mm]	f [mm]	k ₁ [mm]
PLA-PA 1.4-5	48PA0140055	PLA-PA 1.4-5 FV	48PA0140055FV	2.5	30	6	55	80	8	10
PLA-PA 2.5-8	48PA0250080	PLA-PA 2.5-8 FV	48PA0250080FV		30	10	80	80	8	10
PLA-PA 5.0-12	48PA0500120	PLA-PA 5.0-12 FV	48PA0500120FV	5.0	40	15	120	100	10	10
PLA-PA 10.0-16	48PA1000160	PLA-PA 10.0-16 FV	48PA1000160FV	10.0	60	20	160	140	12	15

Other load levels and anchor lengths on request.

3.4.2 Load Bearing Capacities, Edge and Axis Distances, Additional Reinforcement for Thin Slabs and Pipes

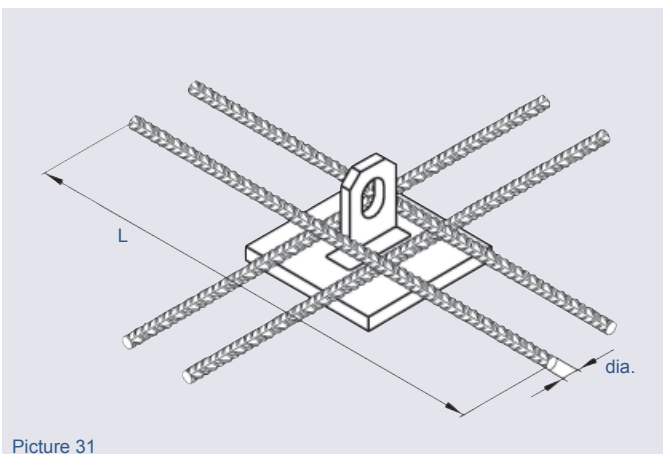

Picture 31

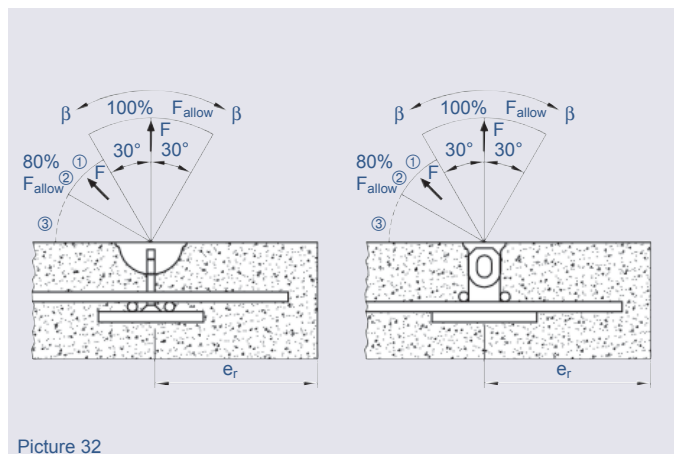

Picture 32

① **Diagonal tension with $30^\circ < \beta \leq 60^\circ$ without additional reinforcement only allowed with:**

- At a concrete strength of $\beta_w \geq 15 \text{ N/mm}^2 + 3\text{-fold min. thickness of unit}$
- At a concrete strength of $\beta_w \geq 25 \text{ N/mm}^2 + 2,5\text{-fold min. thickness of unit}$
- At a concrete strength of $\beta_w \geq 35 \text{ N/mm}^2 + 2\text{-fold min. thickness of unit}$

② **Where concrete strength $\beta_w \geq 23 \text{ N/mm}^2$ F_{allow} can be taken as 100%.**

③ **Angle of $\beta > 60^\circ$ due to cable spread are inadmissible!**

Table 17: Reinforcement; Concrete Strength $\beta_w \geq 15 \text{ N/mm}^2$

Designation	Load Group	Anchor Length	Minimum Edge / Center Distance			Additional Reinforcement		100% F_{allow} Tension $\beta \leq 30^\circ$	80% F_{allow} Lateral Tension $\beta > 30^\circ$
			d [mm]	e_r [mm]	e_z [mm]	dia. [mm]	L [mm]	[kN]	[kN]
PLA-PA 1.4-5	2.5	55	115	230	8	200	14	11.2	
PLA-PA 2.5-8		80	165	330	10	300	25	20.0	
PLA-PA 5.0-12	5.0	120	240	480	12	450	50	40.0	
PLA-PA 10.0-16	10.0	160	330	660	16	600	100	80.0	

3.5 Flat Foot Anchor PLA-FF

3.5.1 Anchor Dimensions PLA-FF

This anchor is an alternative to the plate anchor PLA-AK-FP. The main use is in elements with a concrete strength at lifting in excess of 25 N/mm².

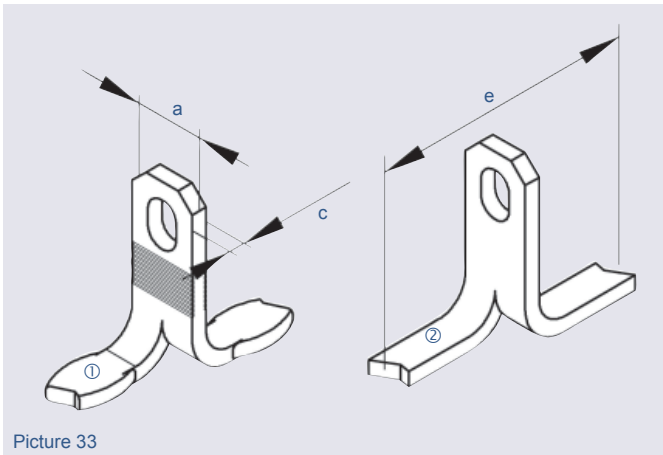

Picture 33

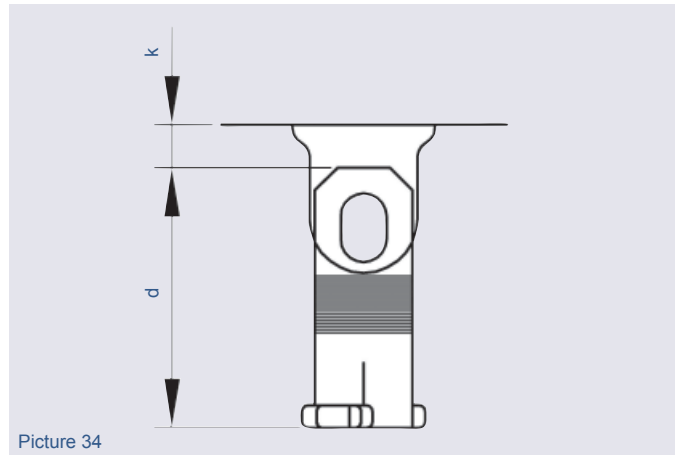

Picture 34

- ① Load rate 2.5t - 5.0t
- ② Load rate 10.0t - 26.0t

Table 18: Dimensions Flat Foot Anchor PLA-FF

Designation bright	Art.-No.	Designation hot-dip galvanized	Art.-No.	Load Group	a [mm]	c [mm]	d [mm]	e [mm]	k [mm]
PLA-FF 0.7-6	48FF007065	PLA-FF 0.7-6 FV	48FF007065FV	2.5	30	5	65	70	10
PLA-FF 1.4-6	48FF014065	PLA-FF 1.4-6 FV	48FF014065FV		30	6	65	70	
PLA-FF 2.0-7	48FF020070	PLA-FF 2.0-7 FV	48FF020070FV		30	8	70	80	
PLA-FF 2.5-7	48FF020075	PLA-FF 2.5-7 FV	48FF020075FV		30	10	75	94	
PLA-FF 3.0-9	48FF030090	PLA-FF 3.0-9 FV	48FF030090FV	5.0	40	10	90	100	10
PLA-FF 4.0-11	48FF040110	PLA-FF 4.0-11FV	48FF040110FV		40	12	110	100	
PLA-FF 5.0-12	48FF050125	PLA-FF 5.0-12FV	48FF050125FV		40	15	125	105	
PLA-FF 7.5-17	48FF075170	PLA-FF 7.5-17FV	48FF075170FV	10.0	60	16	170	120	15
PLA-FF 10.0-20	48FF100200	PLA-FF 10.0-20FV	48FF100200FV		60	20	200	120	
PLA-FF 12.5-22	48FF125220	PLA-FF 12.5-22FV	48FF125220FV	26.0	80	16	220	200	15
PLA-FF 17.0-27	48FF170270	PLA-FF 17.0-27FV	48FF170270FV		80	20	270	200	
PLA-FF 22.0-31	48FF220310	PLA-FF 22.0-31FV	48FF220310FV		90	28	310	200	

3.5.2 Reinforcement of the Anchor Zone

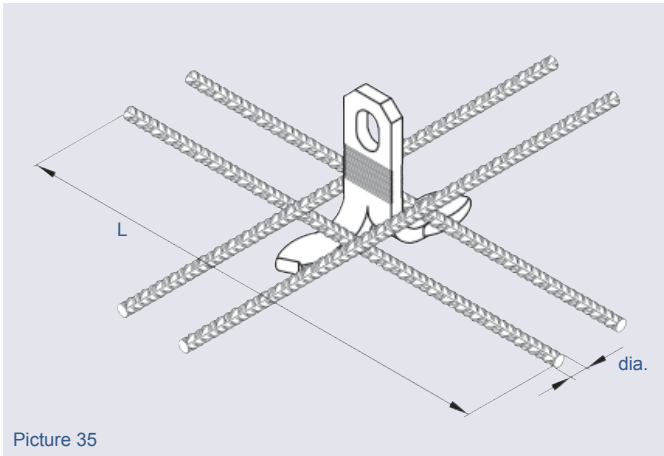

Picture 35

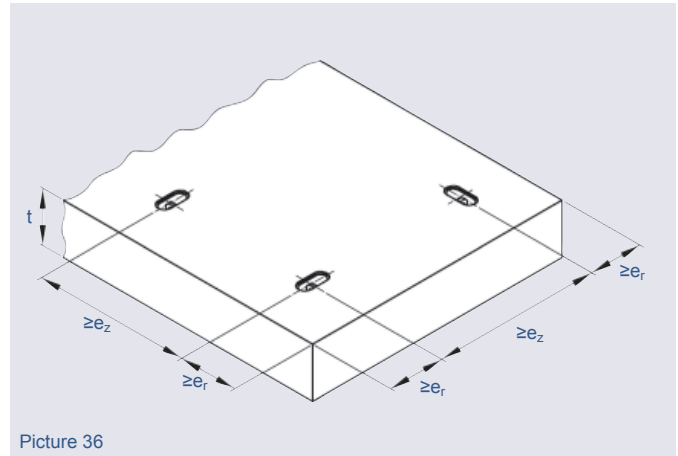

Picture 36

Where loads are acting towards the edge of the element, insert angled pull reinforcement as for spread or two hole anchors.

Table 19: Reinforcement in the Anchor Zone

Designation	Load Group	Anchor Length	Minimum Unit Thickness	Minimum Edge/Center Distance		Additional Reinforcement BSt 500 S		Load Bearing Capacity, Axial, Diagonal and Lateral Tension at a Concrete Strength β_w at Lifting		
				e_r [mm]	e_z [mm]	dia. [mm]	L [mm]	$\geq 15 \text{ N/mm}^2$ [kN]	$\geq 25 \text{ N/mm}^2$ [kN]	$\geq 35 \text{ N/mm}^2$ [kN]
PLA-FF 0.7-6	2.5	65	95*	140	280	8	200	7.0	7.0	7.0
PLA-FF 1.4-6		65	95*	140	280	8	250	14.0	14.0	14.0
PLA-FF 2.0-7		70	100*	150	300	8	300	18.0	20.0	20.0
PLA-FF 2.5-7		75	105*	160	320	8	300	20.0	25.0	25.0
PLA-FF 3.0-9	5.0	90	120	190	380	10	400	28.0	30.0	30.0
PLA-FF 4.0-11		110	140	230	460	12	450	37.0	40.0	40.0
PLA-FF 5.0-12		125	160	260	520	12	500	44.0	50.0	50.0
PLA-FF 7.5-17	10.0	170	215	340	680	14	600	54.6	70.4	75.0
PLA-FF 10.0-20		200	245	400	800	14	600	75.5	100.0	100.0
PLA-FF 14.0-22	26.0	220	265	440	880	16	750	88.5	125.0	125.0
PLA-FF 26.0-27		270	315	540	1080	16	900	120.3	170.0	170.0
PLA-FF 26.0-31		310	355	620	1240	20	1100	148.0	220.0	220.0

* If corrosion protection is assured, the plate thickness can be reduced.

3.6 Garage Anchor PLA-GA

3.6.1 Anchor Dimensions PLA-GA

This anchor is designed for special applications, such as thin floors of precast garages. The plate anchor with erection anchor head permits high angled pull for handling units in areas with a very restricted access height. In the case of axial and angled pull at $\beta < 45^\circ$ (spread of cable $< 90^\circ$), the permissible loads as per the table must be reduced by 50%. The concrete strength must be at least $\beta_w \geq 25 \text{ N/mm}^2$.

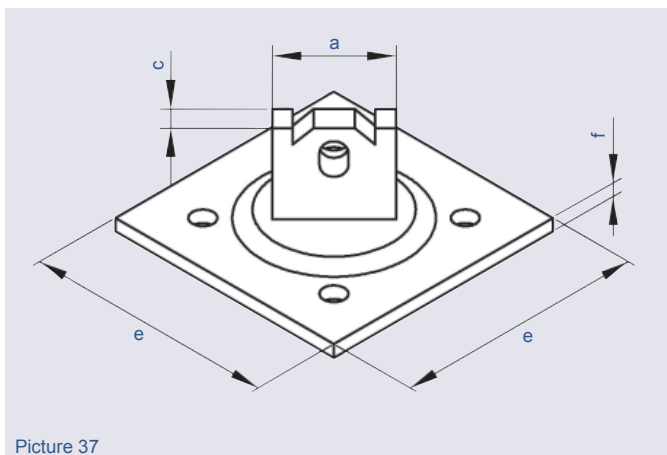

Picture 37

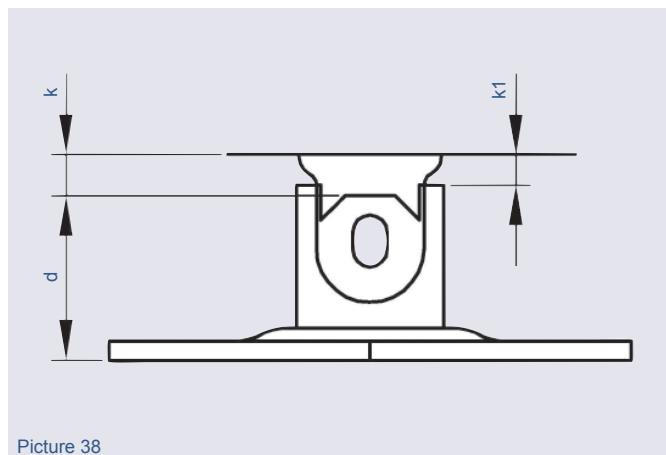

Picture 38

Table 20: Dimensions Plate Anchor PLA-GA

Designation	Art.-No.	Load Group	a [mm]	c [mm]	d [mm]	e [mm]	f [mm]	k [mm]	k ₁ [mm]
PLA-GA 4.0-7	48GA040067	5.0	60	16	67	150	8	10	5

3.6.2 Load Bearing Capacity, Edge and Center Distance for Thin Plates and Tubes

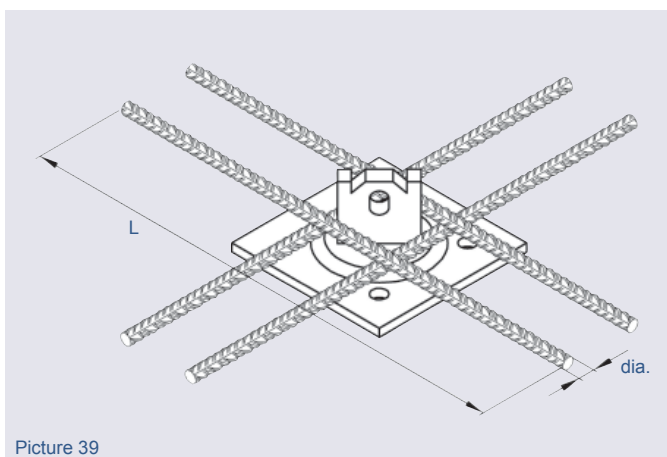

Picture 39

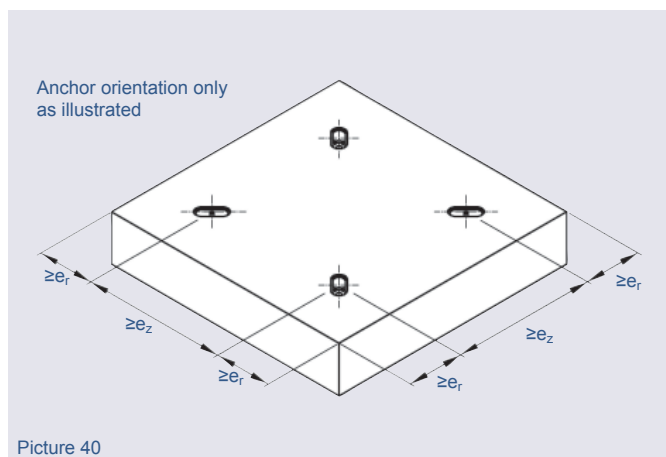

Picture 40

Table 21: Reinforcement, Concrete Strength $\beta_w \geq 25\text{N/mm}^2$

Designation	Load Group	Anchor Length	Minimum Edge and Center Distance		Additional Reinforcement		Load Bearing Capacity  (for $\beta > 45^\circ$) [kN]
		d [mm]	e _r [mm]	e _z [mm]	dia. [mm]	L [mm]	
PLA-GA 4.0-7	5.0	67	240	480	12	450	40

① β = inclination of the rope, at $\beta < 45^\circ$ see text above

3.7 Double Ended Column Anchor PLA-DK

3.7.1 Anchor Dimensions PLA-DK

This anchor is identical to the head of the two hole anchor. It was specially developed for the tilting of columns or similar construction elements.

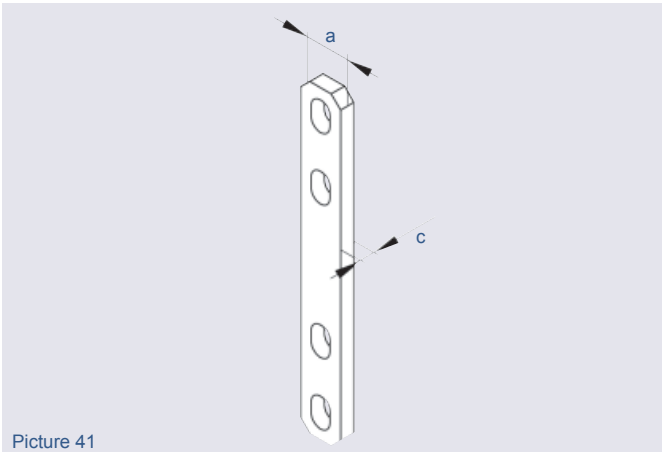

Picture 41

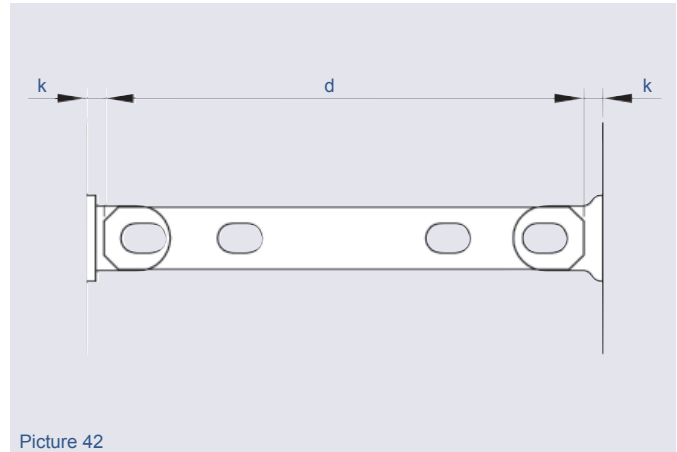

Picture 42

Table 22: Dimensions Double Ended Column Anchor PLA-DK

Designation bright	Art.-No.	Designation hot-dip galvanized	Art.-No.	Load Group	Column Breath [mm]	a [mm]	c [mm]	d [mm]	k [mm]
PLA-DK 2.5-23	48DK025228	PLA-DK 2.5-23 FV	48DK025228FV	2.5	250	30	10	228	10
PLA-DK 2.5-28	48DK025278	PLA-DK 2.5-28 FV	48DK025278FV		300	30	10	278	
PLA-DK 2.5-33	48DK025328	PLA-DK 2.5-33 FV	48DK025328FV		350	30	10	328	
PLA-DK 5.0-23	48DK050226	PLA-DK 5.0-23 FV	48DK050226FV	5.0	250	40	15	226	10
PLA-DK 5.0-28	48DK050276	PLA-DK 5.0-28 FV	48DK050276FV		300	40	15	276	
PLA-DK 5.0-33	48DK050326	PLA-DK 5.0-33 FV	48DK050326FV		350	40	15	326	
PLA-DK 5.0-38	48DK050376	PLA-DK 5.0-38 FV	48DK050376FV		400	40	15	376	
PLA-DK 5.0-43	48DK050426	PLA-DK 5.0-43 FV	48DK050426FV		450	40	15	426	
PLA-DK 5.0-48	48DK050476	PLA-DK 5.0-48 FV	48DK050476FV		500	40	15	476	
PLA-DK 7.5-26	48DK075262	PLA-DK 7.5-26 FV	48DK075262FV		10.0	300	60	16	
PLA-DK 7.5-31	48DK075312	PLA-DK 7.5-31 FV	48DK075312FV	350		60	16	312	
PLA-DK 7.5-36	48DK075362	PLA-DK 7.5-36 FV	48DK075362FV	400		60	16	362	
PLA-DK 7.5-41	48DK075412	PLA-DK 7.5-41 FV	48DK075412FV	450		60	16	412	
PLA-DK 7.5-46	48DK075462	PLA-DK 7.5-46 FV	48DK075462FV	500		60	16	462	
PLA-DK 10.0-26	48DK100262	PLA-DK 10.0-26 FV	48DK100262FV	300		60	20	262	
PLA-DK 10.0-31	48DK100312	PLA-DK 10.0-31 FV	48DK100312FV	350		60	20	312	
PLA-DK 10.0-36	48DK100362	PLA-DK 10.0-36 FV	48DK100362FV	400		60	20	362	
PLA-DK 10.0-41	48DK100412	PLA-DK 10.0-41 FV	48DK100412FV	450		60	20	412	
PLA-DK 10.0-46	48DK100462	PLA-DK 10.0-46 FV	48DK100462FV	500		60	20	462	
PLA-DK 12.5-36	48DK125362	PLA-DK 12.5-36 FV	48DK125362FV	26.0	400	80	16	362	15
PLA-DK 12.5-41	48DK125412	PLA-DK 12.5-41 FV	48DK125412FV		450	80	16	412	
PLA-DK 12.5-46	48DK125462	PLA-DK 12.5-46 FV	48DK125462FV		500	80	16	462	
PLA-DK 17.0-36	48DK170362	PLA-DK 17.0-36 FV	48DK170362FV		400	80	20	362	
PLA-DK 17.0-41	48DK170412	PLA-DK 17.0-41 FV	48DK170412FV		450	80	20	412	
PLA-DK 17.0-46	48DK170462	PLA-DK 17.0-46 FV	48DK170462FV		500	80	20	462	
PLA-DK 22.0-41	48DK220412	PLA-DK 22.0-41 FV	48DK220412FV	26.0	450	90	28	412	15
PLA-DK 22.0-46	48DK220462	PLA-DK 22.0-46 FV	48DK220462FV		500	90	28	462	
PLA-DK 22.0-56	48DK220562	PLA-DK 22.0-56 FV	48DK220562FV		600	90	28	562	

Other anchor lengths on request.

3.7.2 Load Bearing Capacity, Reinforcement Double Ended Column Anchor PLA-DK

The anchor is capped with the appropriate recess former at both ends. The assembly of anchor and recess formers is then pushed between the reinforcement bars and fastened to the formwork at both ends. The additional reinforcement bars are then pushed through the holes of the anchor and wired into place. The diameter of the reinforcement tails is the same as for the two hole anchor.

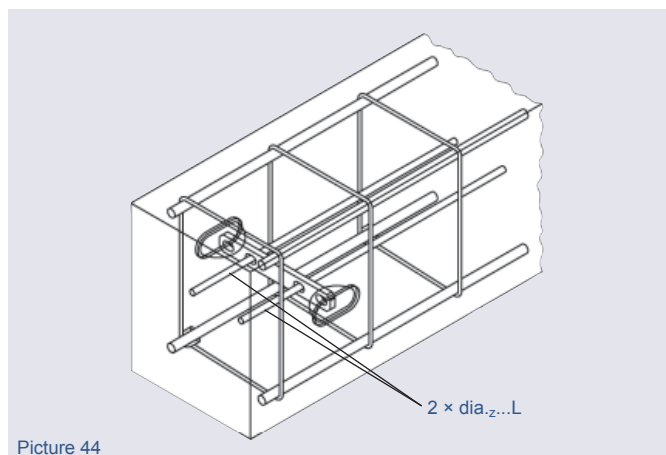
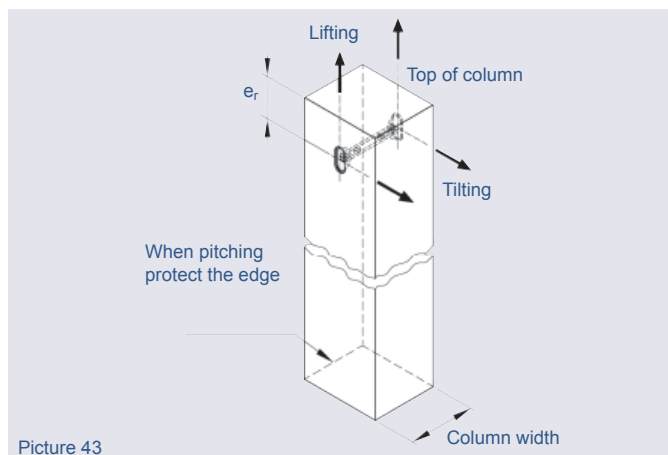



Note:

The larger the dimension e_r , the greater the load on the anchor when tilting, but the lower the load on the edge at the base of the column.

Table 23: Load Bearing Capacity, Reinforcement Double Ended Column Anchor PLA-DK

Designation	Load Group	Reinforcement		Load Bearing Capacity	
		dia_z [mm]	L [mm]	for $\beta_w \geq 15$ N/mm ² [kN]	for $\beta_w \geq 25$ N/mm ² [kN]
PLA-DK 2.5-23	2.5	12	750	40	50
PLA-DK 2.5-28		12	750	40	50
PLA-DK 2.5-33		12	750	40	50
PLA-DK 5.0-23	5.0	16	1000	80	100
PLA-DK 5.0-28		16	1000	80	100
PLA-DK 5.0-33		16	1000	80	100
PLA-DK 5.0-38		16	1000	80	100
PLA-DK 5.0-43		16	1000	80	100
PLA-DK 5.0-48		16	1000	80	100

Continuation Table 23: Load Bearing Capacity, Reinforcement Double Ended Column Anchor PLA-DK

Designation	Load Group	Reinforcement		Load Bearing Capacity	
		dia.z [mm]	L [mm]	 for $\beta_w \geq 15$ N/mm ² [kN]	 for $\beta_w \geq 25$ N/mm ² [kN]
PLA-DK 7.5-26	10.0	20	1200	120	150
PLA-DK 7.5-31		20	1200	120	150
PLA-DK 7.5-36		20	1200	120	150
PLA-DK 7.5-41		20	1200	120	150
PLA-DK 7.5-46		20	1200	120	150
PLA-DK 10.0-26		25	1500	160	200
PLA-DK 10.0-31		25	1500	160	200
PLA-DK 10.0-36		25	1500	160	200
PLA-DK 10.0-41		25	1500	160	200
PLA-DK 10.0-46		25	1500	160	200
PLA-DK 12.5-36	26.0	25	1500	200	250
PLA-DK 12.5-41		25	1500	200	250
PLA-DK 12.5-46		25	1500	200	250
PLA-DK 17.0-36		28	1600	272	340
PLA-DK 17.0-41		28	1600	272	340
PLA-DK 17.0-46		28	1600	272	340
PLA-DK 22.0-41		28	2000	352	440
PLA-DK 22.0-46		28	2000	352	440
PLA-DK 22.0-56		28	2000	352	440

3.8 Sandwich Panel Anchor PLA-SW

3.8.1 Dimensions PLA-SW

This anchor is specially designed for use with precast sandwich panels. It's suspension point is close to the gravity axis thus allowing the element to be transported and erected in an upright position. To ensure a sufficient corrosion protection, we suggest hot-dipped quality.

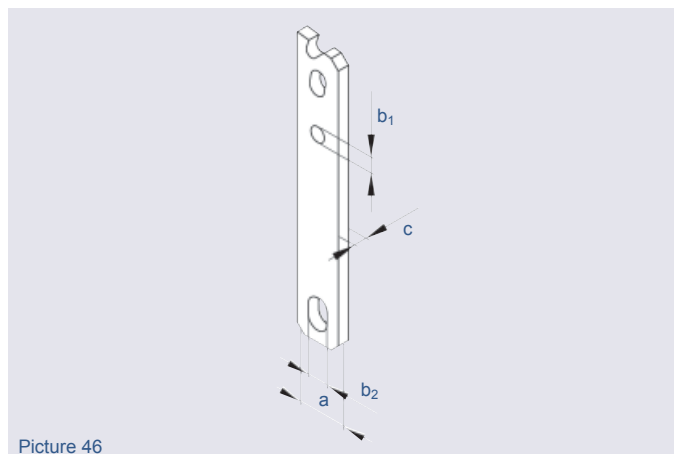
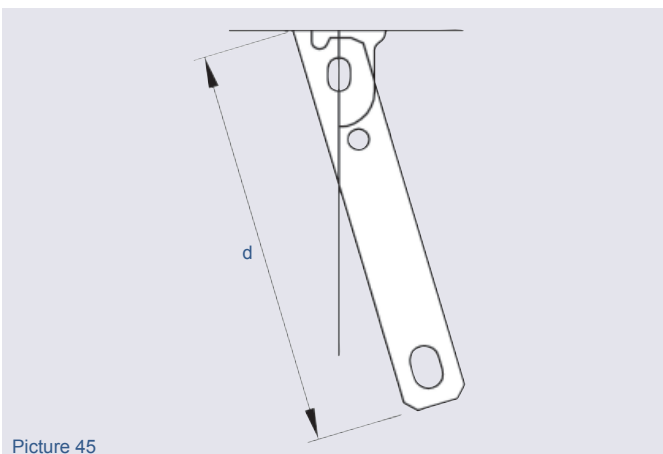
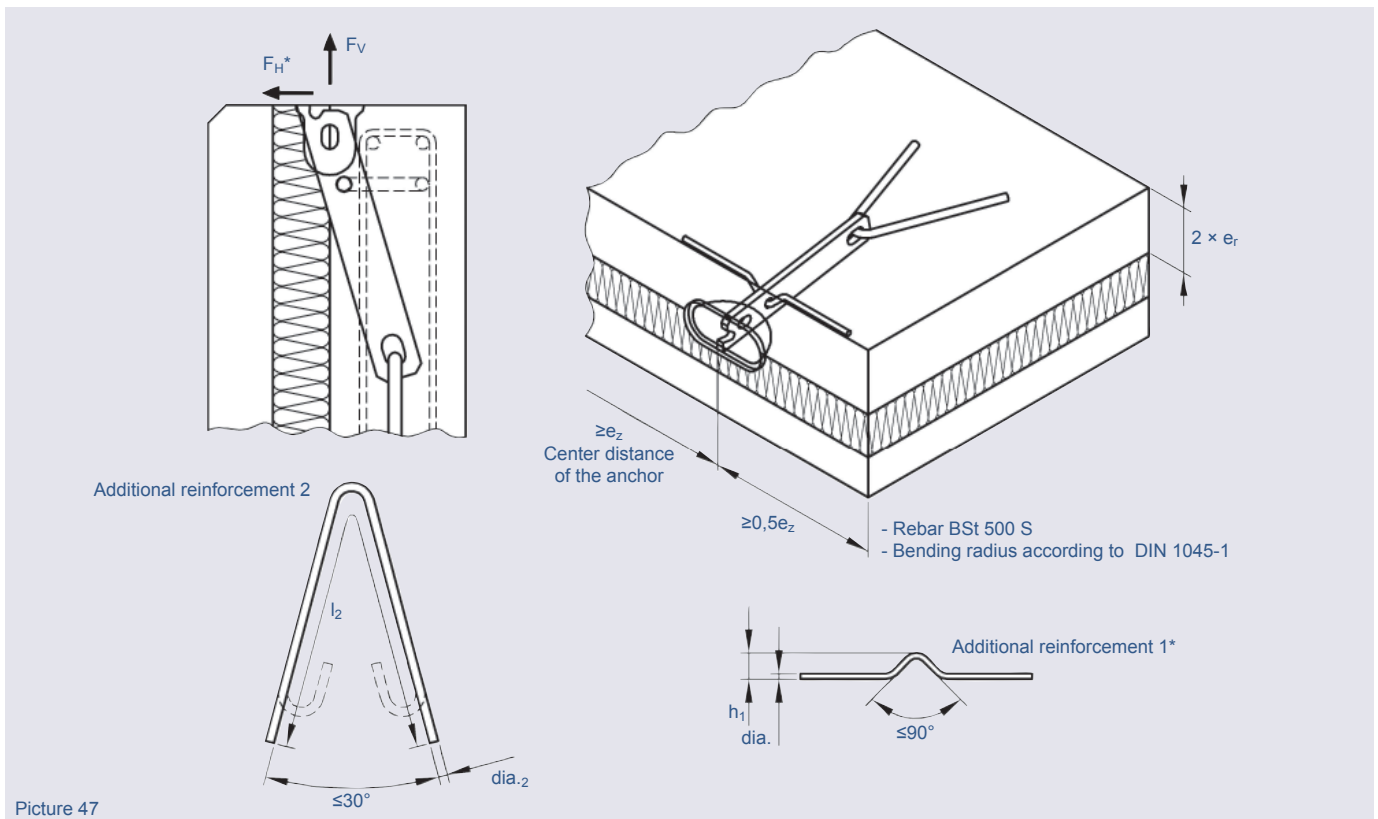

Table 24: Dimensions Sandwich Panel Anchor PLA-SW

Designation bright	Art.-No.	Designation hot-dip galvanized	Art.-No.	Load Group	a [mm]	b ₁ [mm]	b ₂ [mm]	c [mm]	d [mm]
PLA-SW 2.5-25	48SW025250	PLA-SW 2.5-25 FV	48SW025250FV	2.5	40	14.0	18	10	250
PLA-SW 5.0-30	48SW050300	PLA-SW 5.0-30 FV	48SW050300FV	5.0	60	17.5	26	16	300
PLA-SW 7.5-35	48SW075350	PLA-SW 7.5-35 FV	48SW075350FV	10.0	80	25.0	35	16	350
PLA-SW 10.0-35	48SW100350	PLA-SW 10.0-35 FV	48SW100350FV		80	25.0	35	20	350
PLA-SW 17.0-40	48SW170400	PLA-SW 17.0-40 FV	48SW170400FV	26.0	100	30.0	35	20	400

3.8.2 Reinforcement PLA-SW

The specially designed sloping head of the sandwich panel anchor type PLA-SW can be inserted close to the gravity axis in large precast concrete sandwich-panels. The panel hangs nearly upright during transportation and installation. The head shape is compatible with the range of PLA-hole anchor accessories.



Picture 47

- L_w = length prior bending
- h₁ according to unit thickness, but at least the table value
- * only required, if F_H exists in this direction, e.g. at positive production

Table 25: Reinforcement; Concrete Strength $\beta_w \geq 15 \text{ N/mm}^2$

Designation	Load Group	$2 \times e_r$ [mm]	Stirrups for Tension BSt 500 S n dia. ... $\times L_1$ [mm]	Additional Reinforcement 1 ^① (not included in delivery)			Additional Reinforcement 2 (not included in delivery)		Load Bearing Capacity		Recommended Recess Former
				dia. ₁ [mm]	L _w [mm]	h ₁ [mm]	dia. ₂ [mm]	l ₁ [mm]	[kN]	[kN]	
PLA-SW 2.5-25	2.5	100	2 dia. 8 \times 600	10	600	≥ 60	14	800	25	8	PLA-AK-A1 2.5
PLA-SW 5.0-30	5.0	120	2 dia. 8 \times 800	14	700	≥ 80	16	1200	50	18	PLA-AK-A1 5.0
PLA-SW 7.5-35	10.0	130	2 dia. 10 \times 800	16	800	≥ 100	25	1400	75	26	PLA-AK-A1 10.0
PLA-SW 10.0-35		140	4 dia. 10 \times 800	20	900	≥ 120	25	1800	100	35	PLA-AK-A1 10.0
PLA-SW 17.0-40	26.0	180	4 dia. 12 \times 1200	20	1100	≥ 140	28	2500	170	50	PLA-AK-A1 26.0

① to ensure a sufficient corrosion protection we recommend a hot dip galvanized additional reinforcement

3.9 Universal Anchor PLA-UA 1.25-12

3.9.10 Anchor Dimensions, Load Bearing Capacity, Edge and Axis Distances, Reinforcement

This anchor combines the opportunities of spread-, two hole- and erection anchor with a very small recess in the precast element.

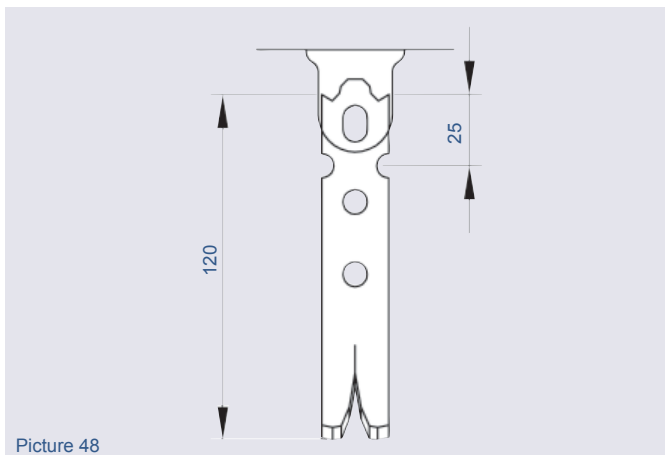

Picture 48

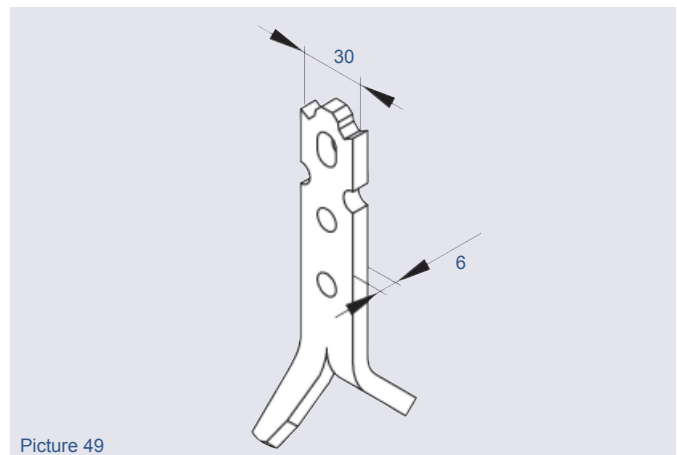

Picture 49

Table 26: Dimensions and Loads of Universal Anchor PLA-UA

Designation bright	Art.-No.	Designation hot-dip galvanized	Art.-No.	Load Group
PLA-UA 1.25-12	48UA012120	PLA-SW 1.25-12 FV	48UA012120FV	1.25

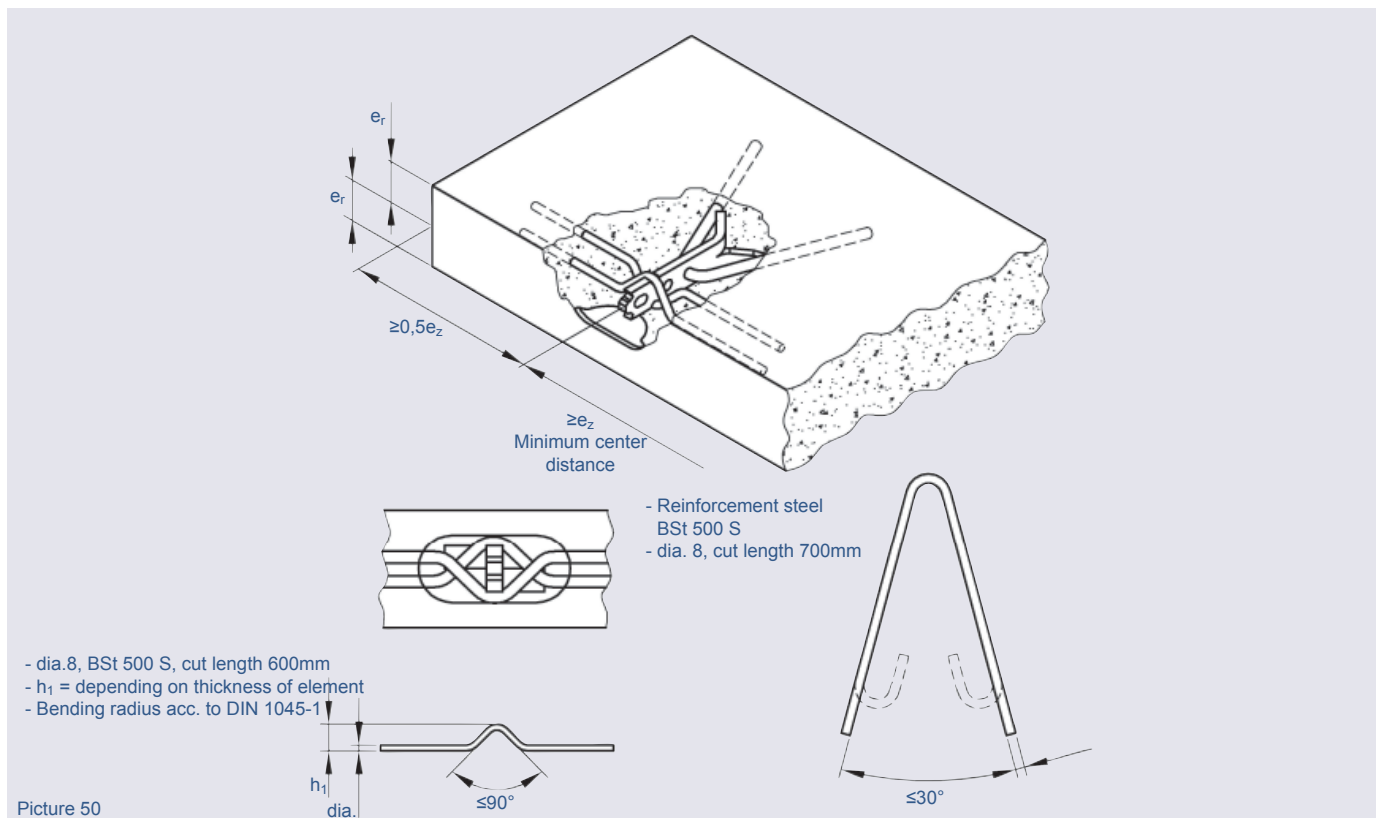

Picture 50

For the handling of very thin precast concrete units (e.g. balcony parapet panels), erection and transport anchors are required, which are especially adapted to those requirements. The **PHILIPP Universal Anchor PLA-UA 1.25-12** has been designed for this specific application, and is ideal for tilting, turning and lifting units in the above situation. Recommended reinforcement: An additional reinforcement tail is essential for distributing the loads in very thin panels or on ones with only a single-layer reinforcement. For turning and tilting, a turning reinforcement must be incorporated.

Table 27: Load Bearing Capacity Universal Anchor PLA-UA

Designation	Minimum Axis distance	Unit Thickness	Axial and Diagonal Tension till 30°			Diagonal Tension till 45°			Tilting and Turning		
			 Load Bearing Capacity at Concrete Strength			 Load Bearing Capacity at Concrete Strength			 Load Bearing Capacity at Concrete Strength		
			$\beta_w = 15\text{N/mm}^2$	$\beta_w = 25\text{N/mm}^2$	$\beta_w = 35\text{N/mm}^2$	$\beta_w = 15\text{N/mm}^2$	$\beta_w = 25\text{N/mm}^2$	$\beta_w = 35\text{N/mm}^2$	$\beta_w = 15\text{N/mm}^2$	$\beta_w = 25\text{N/mm}^2$	$\beta_w = 35\text{N/mm}^2$
e_z [mm]	$2 \times e_r$ [mm]	[kN]	[kN]	[kN]	[kN]	[kN]	[kN]	[kN]	[kN]	[kN]	
PLA-UA 1.25-12	240	60	10.0 ^①	12.5 ^①	12.5 ^①	10.0 ^①	12.5 ^①	12.5 ^①	-	-	-
		80	12.5 ^①	12.5 ^①	12.5 ^①	10.0 ^①	12.5 ^①	12.5 ^①	4.10	4.60	5.00
		100	12.5 ^①	12.5	12.5	10.0 ^①	12.5	12.5	4.50	5.20	5.60
		120	12.5	12.5	12.5	12.5	12.5	12.5	4.80	5.60	6.00
		140	12.5	12.5	12.5	12.5	12.5	12.5	6.00	6.25	6.25
		160	12.5	12.5	12.5	12.5	12.5	12.5	6.25	6.25	6.25

① with additional Reinforcement dia.8 × 700

4. PHILIPP Ring Clutch

4.1 Ring Clutch PLA-RK with Shackle for Manual Release

The ring clutch consists of a shackle and a clutch head. The shackle is free to move in any direction. The clutch head incorporates a locking bolt which fastens to the anchor. Ring clutches are available in four load groups. There are three or four anchors in each load group.

Lifting devices have to be checked regularly according to instructions on Page 33.

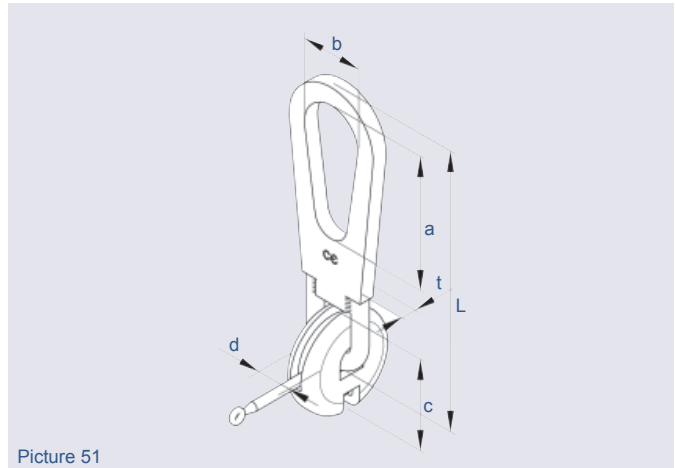

Picture 51

Table 28: PLA-RK

Designation	Art.-No.	Load Group	L [mm]	a [mm]	b [mm]	c [mm]	d [mm]	t [mm]
PLA-RK-R1 2.5	48RK025265	2.5	265	70	58	80	27	12
PLA-RK-R1 5.0	48RK050330	5.0	330	86	65	105	36	16
PLA-RK-R1 10.0	48RK100425	10.0	425	112	90	150	50	25
PLA-RK-R1 26.0	48RK260605	26.0	605	160	120	206	72	30

4.2 Ring Clutch with Wire Cable PLA-RK (for load group 1.25)

Ring clutches with wire cables are subject of the same checkups, namely annual safety inspection by experts, as all other lifting and handling systems. Any damaged wire must be withdrawn from use in strict accordance with the relevant accident prevention regulations for lifting equipment. As the clutch head generally has a much longer life than the pressed cable loops, PHILIPP can fit clutch heads onto new cables if necessary.

Do not combine our products with accessories from other manufacturers. PHILIPP will only guarantee the efficient operation and safety of its ring clutches if it is used in conjunction with original cable loops.

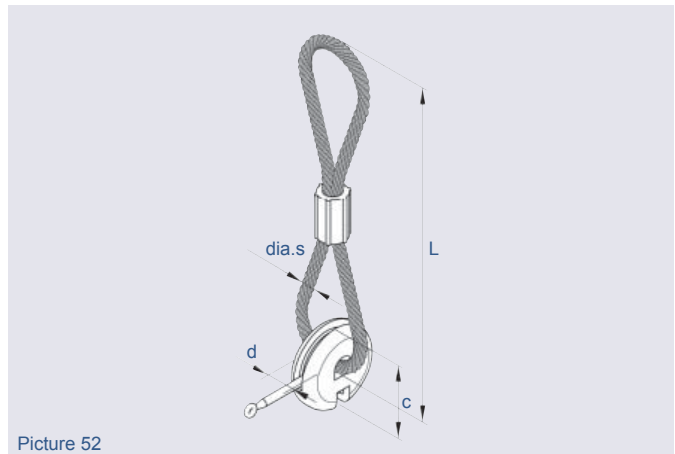

Picture 52

Table 29: PLA-RK

Designation	Art.-No.	Load Group	L [mm]	c [mm]	d [mm]	dia.s [mm]
PLA-RK-R2 1.25	48RK012320	1.25	~ 320	52	20	8

5. Checking of the Lifting Devices

Like all load-carrying devices, ring clutches must be checked at least once annually by an expert for safe operating condition. There is no fixed working life for **PHILIPP Ring Clutches**. Users are expressly warned against combining our products with those of other manufacturers. The correct function and safety of the ring clutches can only be guaranteed when using **PHILIPP Ring Clutches** with original **PHILIPP Anchors**. When checking **PHILIPP Ring Clutches**, the following points should be observed:

5.1 Locking

Ring clutches with worn or bent locking bolts must be taken out of use. For allowable tolerance due to wear see the table below.

Table 30: Nominal Measures of Locking Bolt

Load Group	Nominal Measure d [mm]	Minimum Measure d [mm]
1.25	8.0 +0.4/-0.6	7.0
2.50	13.0 +0.7/-0.4	12.0
5.00	16.5 +0.7/-0.4	15.5
10.00	23.5 +0.8/-0.4	22.5
26.00	32.0 +0.9/-0.5	31.0

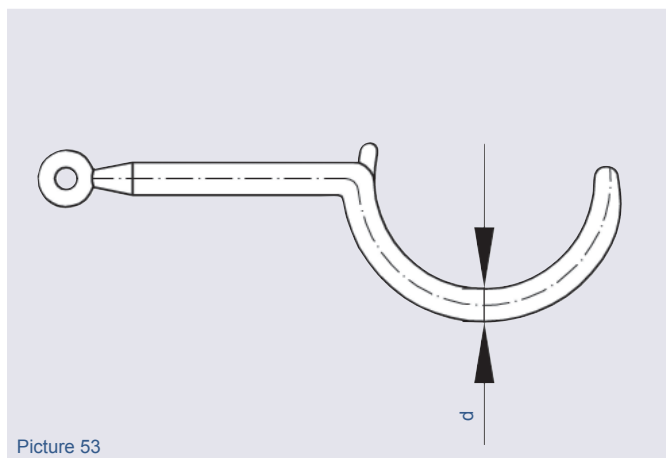

Picture 53

Table 31: Replacement Bolt for Ring Clutch PLA-RK

Load Group	Designation	Art.-No.
1.25	PLA RE1 1.25 Zi	48RE01012
2.50	PLA RE1 2.50 Zi	48RE01025
5.00	PLA RE1 5.00 Zi	48RE01050
10.00	PLA RE1 10.00	48RE01100
26.00	PLA RE1 26.00	48RE01260

5.2 Clutch Head

If the clutch head is deformed or the mouth opening is enlarged, the ring clutch has to be withdrawn and can not be repaired. For allowable tolerance due to wear see the table below.

Table 32: Limiting Measure of Clutch Head

Load Group	Nominal Measure e [mm]	Maximum Measure e [mm]
1.25	7.0 ± 0.12	8.0
2.50	12.0 ± 0.5	13.0
5.00	18.0 + 0.5/-1.0	19.5
10.00	22.0 ± 0.5	23.5
26.00	34.0 + 2.0/-1.0	37.0



Picture 54

5.3 Shackle (PLA-RK 2.5-26.0 tons)

Clutches with visible signs of damage or excessive wear must be withdrawn immediately. For allowable tolerance due to wear see the table below.

Table 33: Limiting Measure of Shackle

Load Group	Nominal Measure f [mm]	Minimum Measure f [mm]
2.5	14	13.0
5.0	20	19.0
10.0	26	25.0
26.0	40	38.5

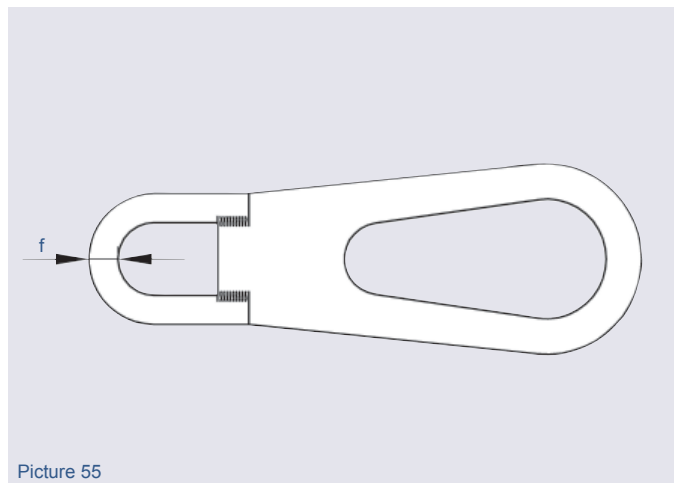

Picture 55

5.4 Wire Cables (PLA-RK 1.25t)

Wire cables should be checked for the following defects:

- Kinking and buckling
- One braid broken
- Slackening of the outermost exposed layer on free length
- Crushing at the eye's contact point with more than 4 ruptured wires on braided cables, or more than 10 ruptured wires on cable laid rope
- High number or ruptured wires
- Crushing on free lengths
- Corrosion marks
- Damage or severe wear to the cable connector or cable end connector

The cable must be replaced if the following numbers of ruptured wires are found (depending from the rope dia.):

Table 34: Replacement Place for Wire Cables

Rope Type	No. of Visible Ruptured Wires over a Length of:		
	3 × dia.	6 × dia.	30 × dia.
Braided Cables	4	6	16

Checking of the wire cables has to include for signs of slipping between the cable and the swaged clamp. Acids, alkaline fluids and other aggressive media, that can cause corrosion, must be kept away from the wire cables. Crane hooks must have a large radius. Sharp-edged hooks or hooks with small cross-section, and therefore small radii, can lead to unacceptable damage of the wire cables. As the clutch head usually has a longer service life than the wire loop, clutch heads with worn wire cables can be exchanged by **PHILIPP**.

6. Application

6.1 Removing the Formwork Sections

Before lifting the precast concrete unit, as many sections of the formwork as possible should be removed in order to minimise adhesion to the formwork. Inadequate stripping is the most common cause of flaking of the precast concrete unit or of anchor failure. The forces acting on the lifting system may be several times the actual weight of the precast unit.

6.2 Removing the Recess Formers

To strip the recess former, two rods are inserted in the holes of the recess former, which is then levered out by scissors action. Only this technique will guarantee a long life time for the recess former. Attempting to remove the recess former using the tip of a hammer will destroy it.

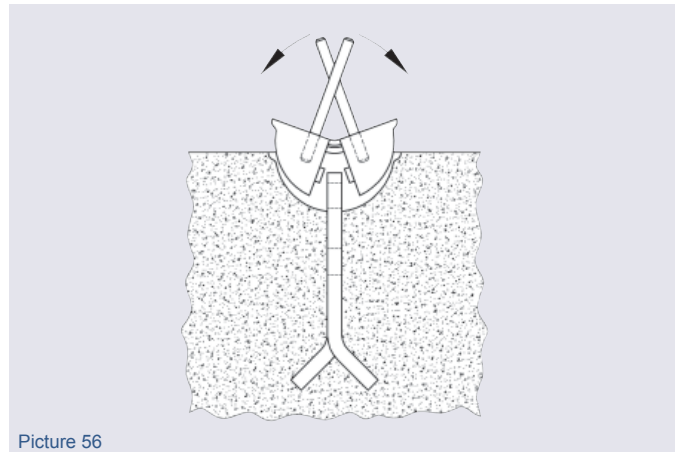

6.3 Fitting the Ring Clutch

To transport an element, the appropriate ring clutch for the load group is inserted over the anchor head in the concrete recess. The load ranges are mismatch-proof.

6.4 Locking the Ring Clutch

The ring clutch is positively locked by a simple hand-operated movement of the locking bolt. The resulting connection is safe, and the ring clutch is free to move in any direction. The precast element can now be lifted out of the formwork and transported safely to its point of storage.

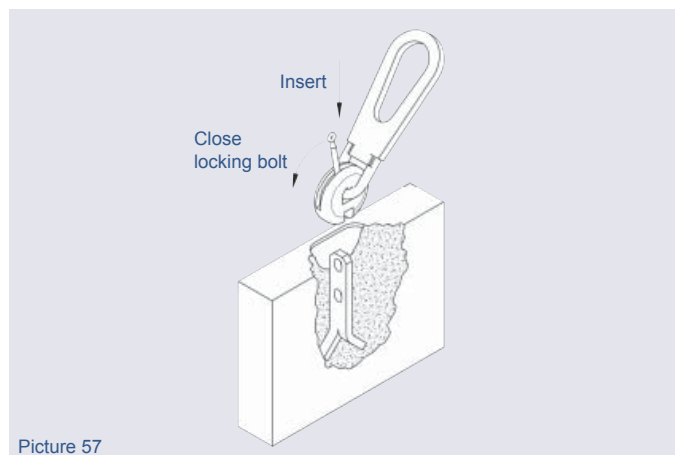

6.5 Installation

A major advantage of the **PHILIPP Hole Anchor System** is that the lifting device (ring clutche) remain attached to the crane hook and do not need to be transported by hand. The ring clutch can be released manually by pushing back the locking bolt once the device is off-load.

6.6 Tilting Slabs without Tilting Table

The **PHILIPP Hole Anchor System** can be used to move flat-manufactured precast units from a horizontal to a vertical position. The direction of pull is at right-angles to the built-in anchor.

To avoid flaking of the concrete, the erection anchor PLA-AB should be properly embedded in the unit. The use of cross-beams when lifting is recommended, in order to avoid torsion.

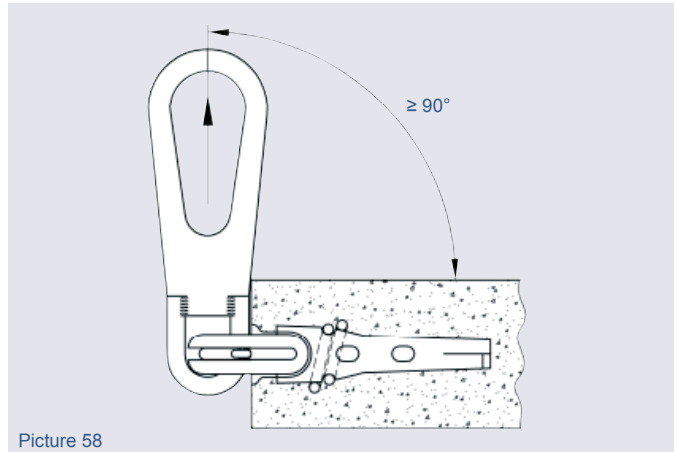

Picture 58

7. Application and Misuse

7.1 Engaging

Insert the ring clutch in the recess in the concrete and close the locking bolt or the slide manually, pushing it to the limit position. Then start the lifting operation.

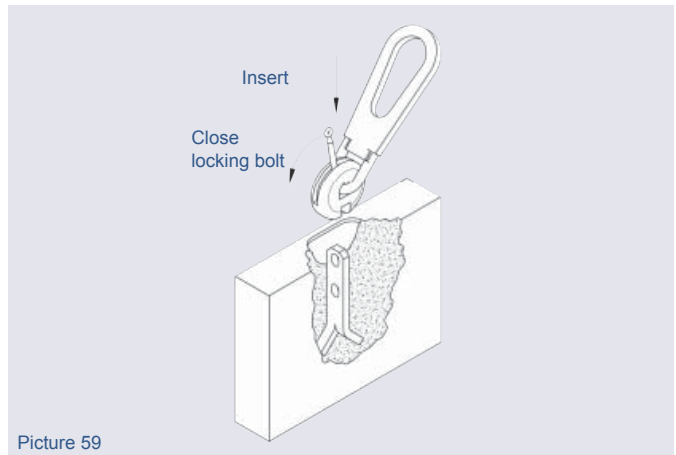

Picture 59

7.2 Handling

The ring clutch can be subjected to loads in any direction (do not exceed the load limits of the anchors!). Angled pull of up to 60° due to the use of a spreader is permissible.

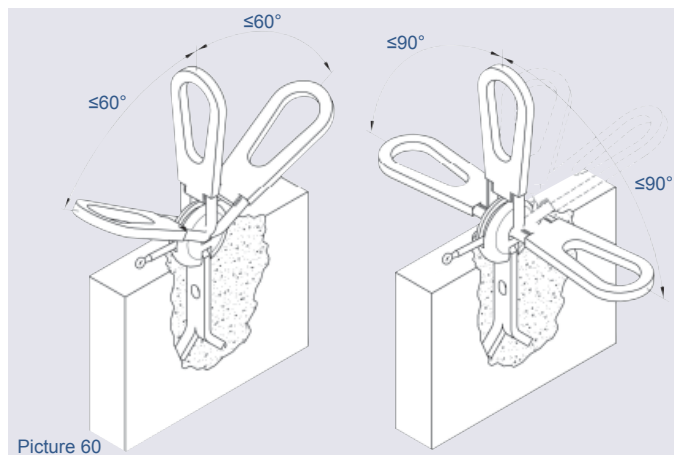

Picture 60

7.3 Releasing

Manual ring clutch: push back the bolt by hand. Now the ring clutch is free.

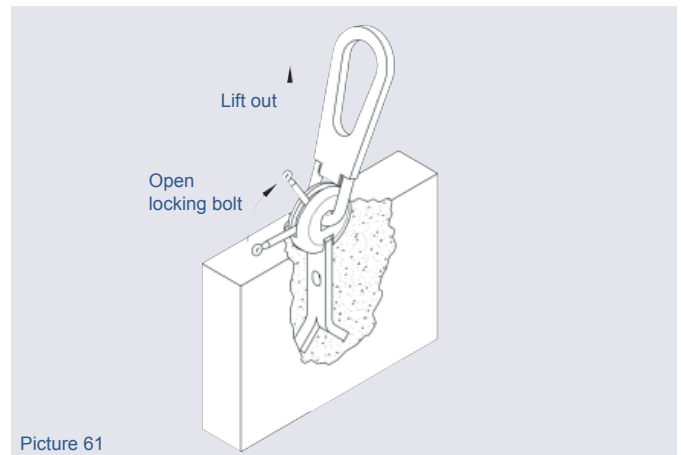

Picture 61

7.4 Misuse of PHILIPP Ring Clutch

If the shackle is beneath the clutch head when subjected to the load, it may lock in the position illustrated. The round shackle will become bent then when the load is raised.

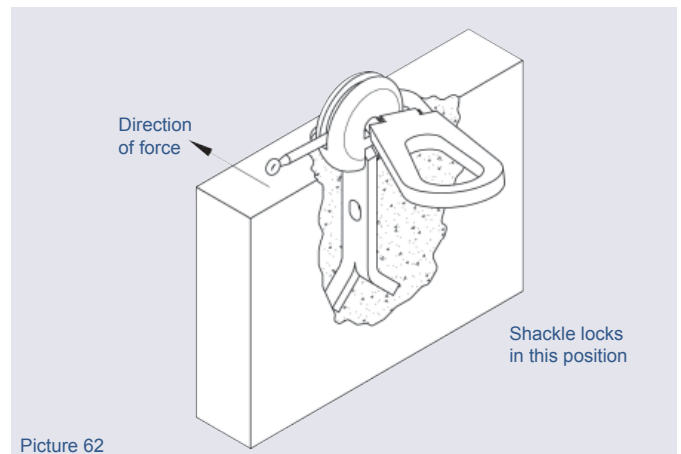

Picture 62

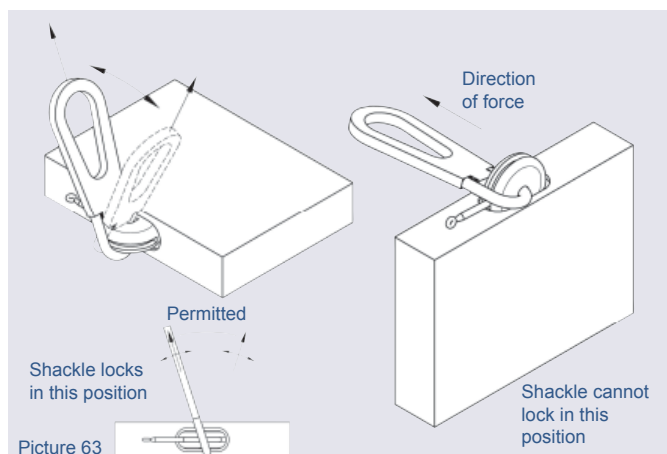

Picture 63

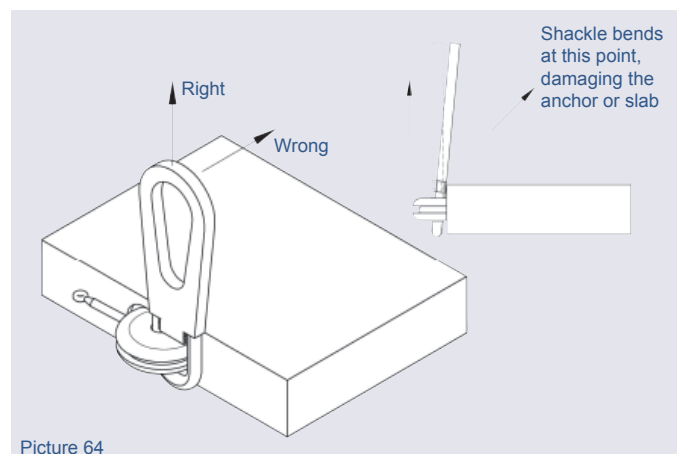

Picture 64

In the upper position, the shackle may lock within the clutch housing. A narrow lifting cable angle will cause the shackle to become bent. The problem can be overcome by turning the shackle through approx. 45° (lower drawing).

If the shackle is pulled towards the top surface of the slab when subjected to the load, it may become bent on the edge of the slab.

8 Recess Former, Holding Plates and Holding Screws

8.1 Recess Former

Recess former for a durable attachment to the formwork. The anchor head is pressed into the foam strips PLA-AK-Z01 and secured in the recess former from the outside with the wedge PLA-AK-E01. The wedge is simply taken out for removal from the formwork.

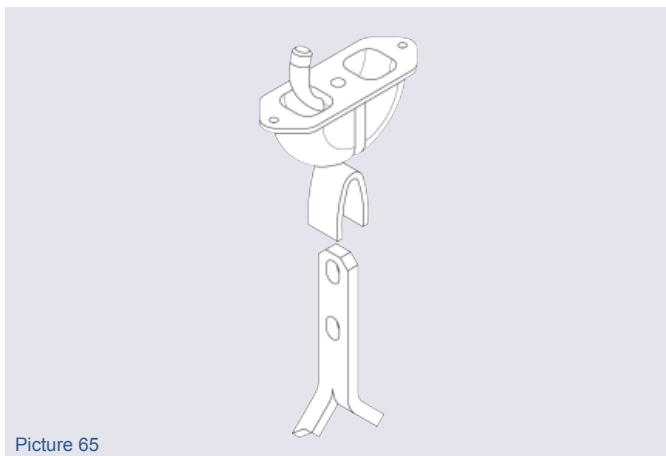

Picture 65

8.2 Holding Plates

The holding plate PLA-AK-H1 consists of a base plate with two bolts. 4 nail holes are provided in the base plate. The plate can either be nailed or welded on. The recess former is simply fitted onto the bolts for installation. The formwork can then simply be pulled off without first having to remove the plate.

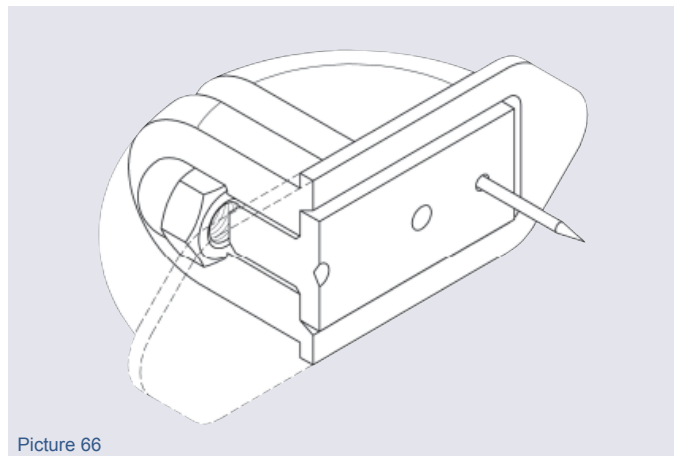

Picture 66

8.3 Holding Screws

The threaded holding screw PLA-AK-S1 is used for bolting on the recess former. It is pressed in at the upper end with a wing nut. An identical wing nut is screwed onto the thread.

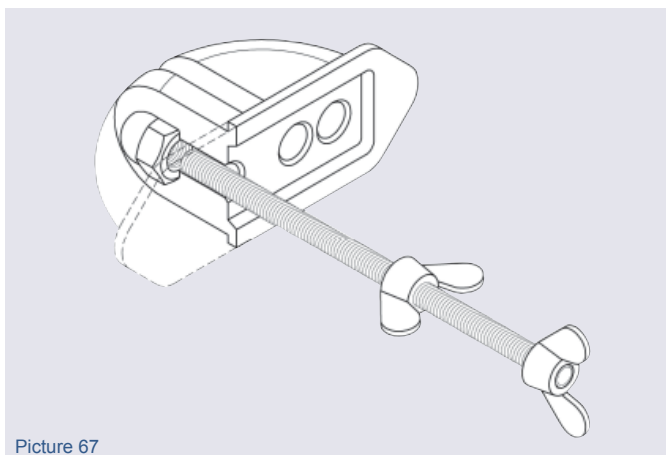

Picture 67

The bayonet holding screw PLA-AK-S2 consists of a threaded holding screw with a pressed-on bayonet fitting. This is inserted into the bayonet connection of the recessed unit and then turned through 90°. The upper wing nut must then be at right-angles to the lengthwise direction of the recessed unit. The recessed former is then drawn onto the formwork with the second wing nut.

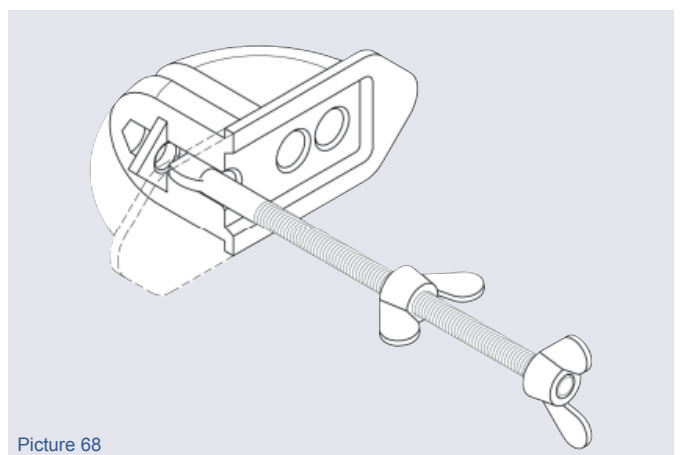

Picture 68

INSTRUCTION FOR INSTALLATION AND USE OF PHILIPP HOLE ANCHOR SYSTEM

8.4 Dimensions Recess Former

Plastic Recess Former PLA-AK-A1		Plastic Recess Former PLA-AK-A9								
Designation	Art.-No.	Designation	Art.-No.	Load Group	a [mm]	b [mm]	c [mm]	Thread M	Colour	
PLA-AK-A1 2.5	48AKA01025	PLA-AK-A9 2.5	48AKA09025	2.5	43	104	45	8	orange	
PLA-AK-A1 5.0	48AKA01050	PLA-AK-A9 5.0	48AKA09050	5.0	49	126	59	8	black	
PLA-AK-A1 10.0	48AKA01100	PLA-AK-A9 10.0	48AKA09100	10.0	67	188	85	12	green	
PLA-AK-A1 26.0	48AKA01260	PLA-AK-A9 26.0	48AKA09260	26.0	112	234	118	16	blue	

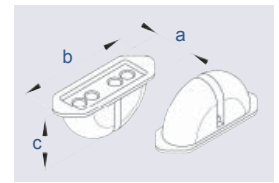

Rubber Recess Former PLA-AK-A2						
Designation	Art.-No.	Load Group	a [mm]	b [mm]	c [mm]	Colour
PLA-AK-A2 2.5	48AKA02025	2.5	41	102	47	orange
PLA-AK-A2 5.0	48AKA02050	5.0	51	126	59	black
PLA-AK-A2 10.0	48AKA02100	10.0	70	184	84	green

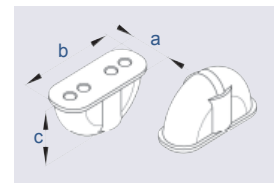

Rubber Recess Former PLA-AK-A3						
Designation	Art.-No.	Load Group	a [mm]	b [mm]	c [mm]	Colour
PLA-AK-A3 5.0	48AKA03050	5.0	54	115	50	black

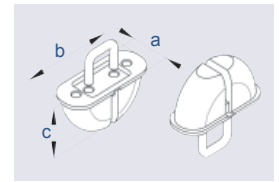

Plastic Recess Former PLA-AK-A4							
Designation	Art.-No.	Load Group	a [mm]	b [mm]	c [mm]	Thread M	Colour
PLA-AK-A4 2.5	48AKA04025	2.5	37	102	45	8	orange
PLA-AK-A4 5.0	48AKA04050	5.0	48	126	59	8	black
PLA-AK-A4 10.0	48AKA04100	10.0	70	184	84	12	green
PLA-AK-A4 26.0	48AKA04260	26.0	112	252	118	16	blue

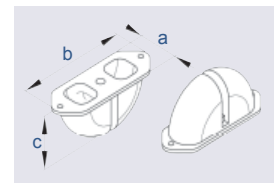

Steel Recess Former PLA-AK-A5 (incl. PLA-AK-E01)						
Designation	Art.-No.	Load Group	a [mm]	b [mm]	c [mm]	Thread M
PLA-AK-A5 2.5	48AKA05025	2.5	37	102	45	8
PLA-AK-A5 5.0	48AKA05050	5.0	48	126	59	8
PLA-AK-A5 10.0	48AKA05100	10.0	70	184	84	12
PLA-AK-A5 26.0	48AKA05260	26.0	112	252	118	16

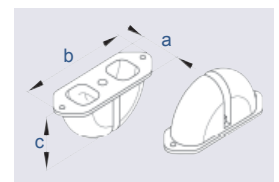

Plastic Recess Former PLA-AK-A7						
Designation	Art.-No.	Load Group	a [mm]	b [mm]	c [mm]	Colour
PLA-AK-A7 1.25	48AKA07012	1.25	28	60	36	blue

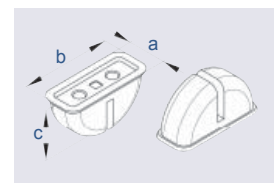

Plastic Recess Former PLA-AK-A8					
Designation	Art.-No.	Load Group	a [mm]	b [mm]	c [mm]
PLA-AK-A8 2.5	48AKA08025	2.5	42	100	47

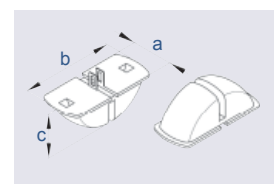

Plastic Recess Former PLA-AK-AM						
Designation	Art.-No.	Load Group	a [mm]	b [mm]	c [mm]	Colour
PLA-AK-AM 2.5	48AKAM025	2.5	43	104	45	orange
PLA-AK-AM 5.0	48AKAM050	5.0	49	126	59	black

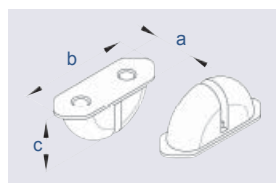

8.5 Dimensions Holding Plates and Holding Screws for Recess Former

Holding Plate PLA-AK-H1 (for Recess Former PLA-AK-A1, PLA-AK-A7, PLA-AK-A9)						
Designation	Art.-No.	Load Group	a [mm]	b [mm]	c [mm]	d [mm]
PLA-AK-H1 1.25	48AKH01012	1.25	40	15	3	8
PLA-AK-H1 2.50	48AKH01025	2.50	70	15	4	10
PLA-AK-H1 5.00	48AKH01050	5.00	85	30	4	10
PLA-AK-H1 10.00	48AKH01100	10.00	125	45	4	12
PLA-AK-H1 26.00	48AKH01260	26.00	175	65	4	

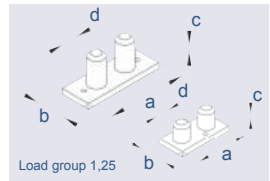

Holding Plate PLA-AK-H2 (for Floating Installation of Recess Former PLA-AK-A1, PLA-AK-A9)						
Designation	Art.-No.	Load Group	a [mm]	b [mm]	c [mm]	d [mm]
PLA-AK-H2 2.5	48AKH02025	2.5	70	15	4	10
PLA-AK-H2 5.0	48AKH02050	5.0	85	30	4	10
PLA-AK-H2 10.0	48AKH02100	10.0	125	45	4	12
PLA-AK-H2 26.0	48AKH02260	26.0	178	65	4	16

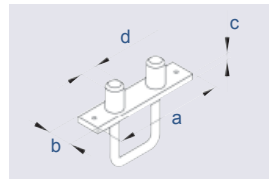

Holding Plate PLA-AK-H3 (for Recess Former PLA-AK-A2)						
Designation	Art.-No.	Load Group	a [mm]	b [mm]	c [mm]	d [mm]
PLA-AK-H3 2.5	48AKH03025	2.5	100	50	4	8
PLA-AK-H3 5.0	48AKH03050	5.0	120	60	4	8
PLA-AK-H3 10.0	48AKH03100	10.0	170	80	4	12

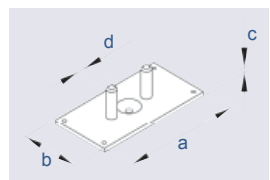

Magnetic Holding Plate PLA-AK-HM (for Recess Former PLA-AK-A1, PLA-AK-A9)						
Designation	Art.-No.	Load Group	a [mm]	b [mm]	c [mm]	d [mm]
PLA-AK-HM 2.5	48AKHM025	2.5	144	63.0	16	10
PLA-AK-HM 5.0	48AKHM050	5.0	144	63.0	16	10
PLA-AK-HM 10.0	48AKHM100	10.0	220	125.5	16	12

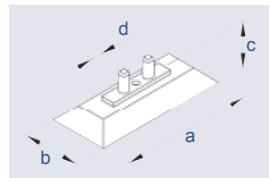

Thread Holding Screw PLA-AK-S1 (for Recess Former PLA-AK-A1, PLA-AK-A2, PLA-AK-A7, PLA-AK-A9, and Holding Plate PLA-AK-H3)					
Designation	Art.-No.	Load Group	a [mm]	dia. [mm]	
PLA-AK-S1 M8	48AKS01050	1.25 2.50 5.00	160	M8	
PLA-AK-S1 M12	48AKS01100	10.00	160	M12	
PLA-AK-S1 M16	48AKS01260	26.00	180	M16	

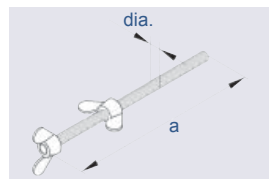

Bayonet Holding Screw PLA-AK-S2 (for Recess Former PLA-AK-A1, PLA-AK-A9)					
Designation	Art.-No.	Load Group	a [mm]	b [mm]	dia. [mm]
PLA-AK-S2 M 8	48AKS02050	2.5 5.0	160	11	M8
PLA-AK-S2 M 12	48AKS02260	10.0 26.0	180	16	M12

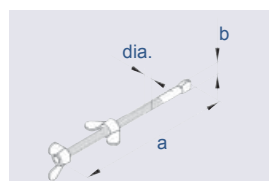

9.9. Accessories

9.1 Recess Filler PLA-AK-V1 (Polystyrene)

If precast concrete units are stored outdoors for any length of time, we recommend the use of our polystyrene recess fillers. The polystyrene recess filler is used to seal off or fill the anchor recess in the precast concrete. It protects the anchor against corrosion and prevents water from collecting in the recess (this could otherwise result in icing-up in cold weather). The recess filler can be used for transport and storage, for a permanent seal once assembly and erection are completed. The recess filler is supplied in the corresponding four load groups and suitable for all recess formers of the load group.

Table 35: Recess Filler PLA-AK-V1

Designation	Art.-No.	Load Group [t]
PLA-AK-V1 2.5	48AKV01025	2.5
PLA-AK-V1 5.0	48AKV01050	5.0
PLA-AK-V1 10.0	48AKV01100	10.0
PLA-AK-V1 26.0	48AKV01260	26.0

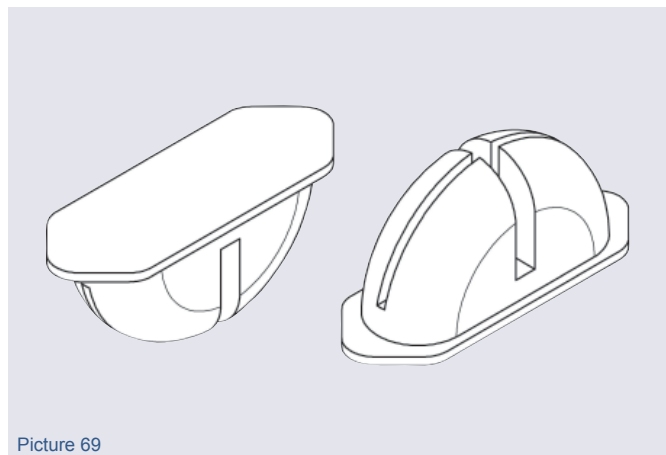

Picture 69

9.1.1 Fitting the Recess Filler

The recess filler is very easy to install. It is simply fitted over the anchor and pressed into the recess.

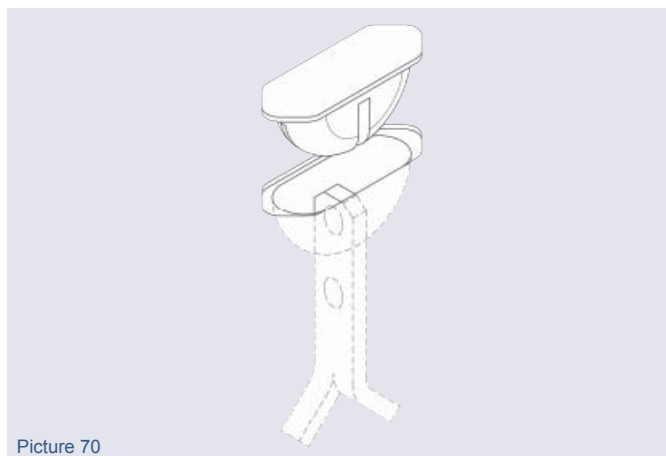

Picture 70

9.2 Foam Strip PLA-AK-Z01 (for PLA-AK-A4 / PLA-AK-A5)

The anchor head is pressed into the foam strips and then inserted into the recessed unit PLA-AK-A4 or PLA-AK-A5. A missing foam strip means that concrete sludge can run into the recess.

Table 36: Form Strips

Designation	Art.-No.	Load Group
PLA-AK-Z01 2.5	48AKZ01025	2.5
PLA-AK-Z01 5.0	48AKZ01050	5.0
PLA-AK-Z01 10.0	48AKZ01100	10.0
PLA-AK-Z01 26.0	48AKZ01260	26.0

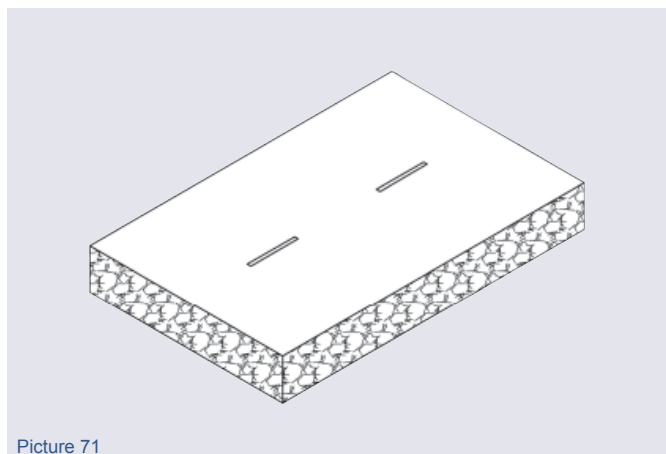

Picture 71

9.3 Spare Wedge PLA-AK-E01 (for PLA-AK-A4 and PLA-AK-A5)

The wedge is used for attachment of the anchor for recess former PLA-AK-A4 and PLA-AK-A5. Then the wedge is simply taken out for removal from the formwork. The wedge supplied with the recess former, although it can also be ordered separately.

Tabelle 37: Spare Wedge

Designation	Art.-No.	Load Group
PLA-AK-E01 2.5	48AKE01025	2.5
PLA-AK-E01 5.0	48AKE01050	5.0
PLA-AK-E01 10.0	48AKE01100	10.0
PLA-AK-E01 26.0	48AKE01260	26.0

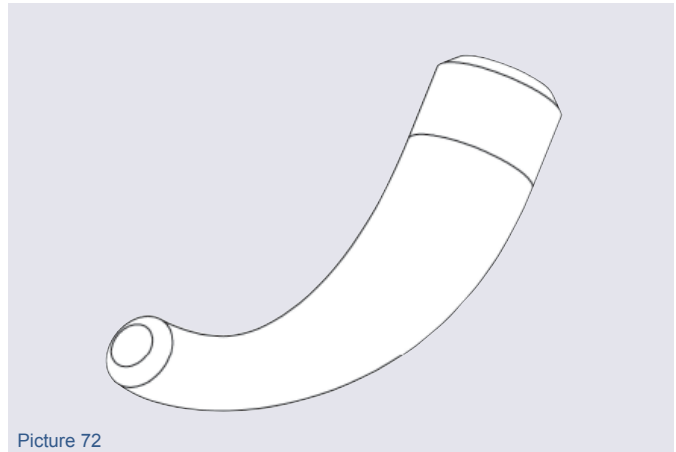

Picture 72

10. Anchor Installation

10.1 Advice and Examples

The anchors must be installed carefully in the interests of efficient functioning and optimum safety. Use the available installation aids for all applications.

10.1.1 Floating Installation

Application for: columns, beams, trusses, π -slabs

Installation aid: **Holding plate H2**

Open up recess former A1 ②, insert anchor ①, press holding plate H2 ③ into recess former and press into the wet concrete.

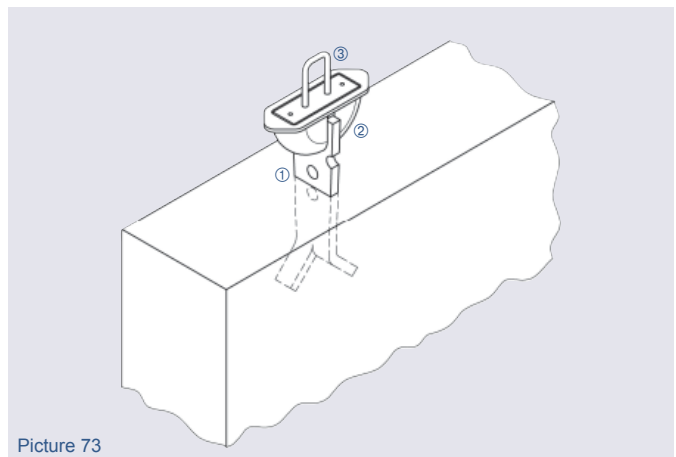

Picture 73

10.1.2 Mounting at the Formwork (timber)

Installation aid: **Holding plate H1**

Nail or screw the holding plate H1 ④ onto the formwork. Press on the recess former A1 ②, with inserted anchor ①. The recess former can be removed more easily, when it was oiled before. We suggest not to nail the recess former onto the mould directly.

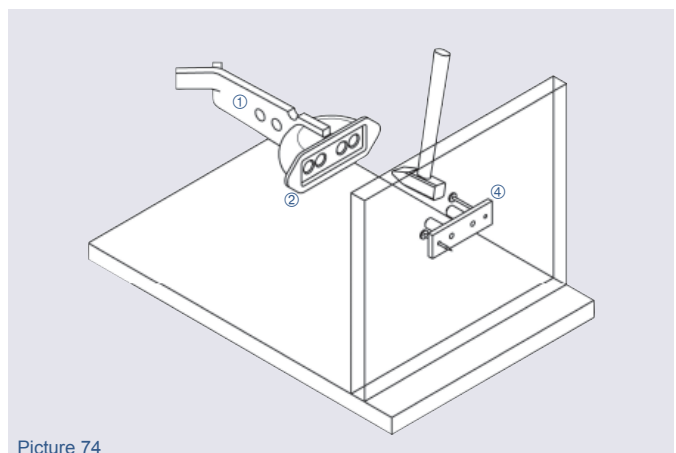

Picture 74

10.1.3 Mounting on the Formwork (timber/steel)

Installation aid: **Holding screw S1 or S2**

Drill through the formwork, push through the holding screw S1 or S2 ⑤, screw into the recess former A1 ②, with inserted anchor ①, draw up against formwork and tighten with wing nut.

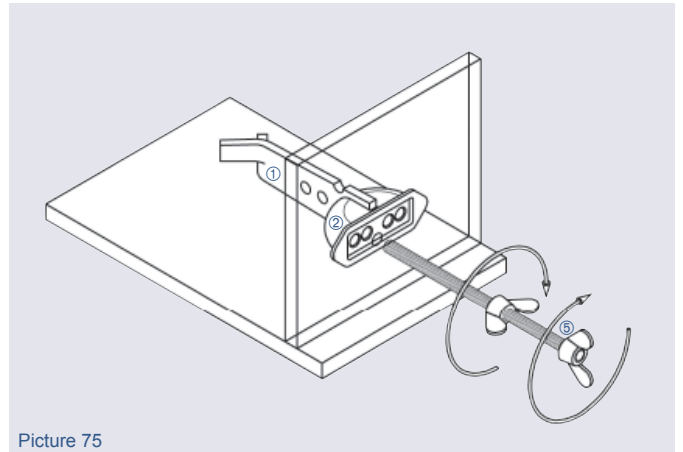

Picture 75

10.1.4 Mounting on the Formwork (steel)

Installation aid: **Magnetic holding plate HM**

Magnetic holding plate ⑥ grips the formwork. Press the recess former A1 ② with inserted anchor ① onto pins.

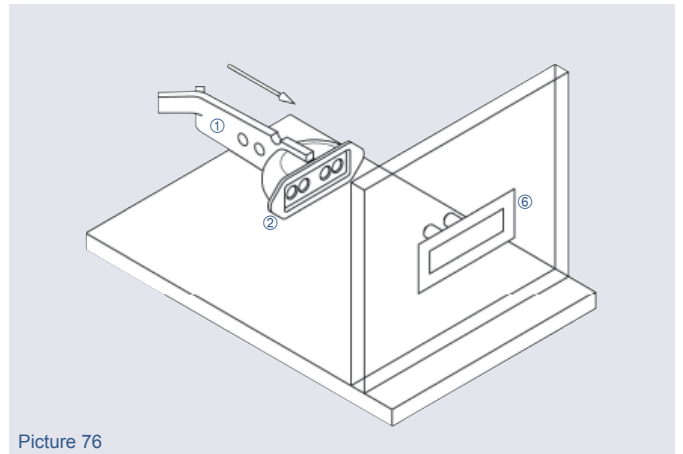

Picture 76

Ropes

- ▲ wire rope slings
- ▲ crane and forest ropes
- ▲ wire, hemp and polyamide ropes
- ▲ hoisting and special ropes
- ▲ polypropylene ropes
- ▲ rope connections



Lifting, attachment and lashing equipment

- ▲ load restraint systems
- ▲ RUD sling chains
- ▲ load suspension devices
- ▲ round slings, sling bands and lifting equipment
- ▲ rope and chain accessories
- ▲ lifting beams



Transport and mounting systems for prefabricated units

- ▲ transport anchors
- ▲ spherical-head anchor system
- ▲ fixing sockets
- ▲ connecting technique



Hydraulic, pneumatics and conveyor technique

- ▲ hydraulic units and components
- ▲ pneumatic, connector systems and accessories
- ▲ Hoses, fittings and accessories
- ▲ machines, tools, machinery systems and accessories

PHILIPP GmbH
Lilienthalstrasse 7-9
D-63741 Aschaffenburg
Tel: + 49 (0) 6021 / 40 27-0
Fax: + 49 (0) 6021 / 40 27-440
info@philipp-group.de
www.philipp-group.de

PHILIPP GmbH
Roßlauer Strasse 70
D-06869 Coswig/Anhalt
Tel: + 49 (0) 34903 / 6 94-0
Fax: + 49 (0) 34903 / 6 94-20
info@philipp-group.de
www.philipp-group.de

PHILIPP GmbH
Sperberweg 37
D-41468 Neuss
Tel: + 49 (0) 2131 / 3 59 18-0
Fax: + 49 (0) 2131 / 3 59 18-10
info@philipp-group.de
www.philipp-group.de

Our Technical support: technik@philipp-gruppe.de