



PHILIPP Dowelling System

Data Sheet



12/08 - EN

Committed. Competent. Your reliable partner.

www.philipp-group.de

The **PHILIPP Dowelling System** is used for the fixation of two concrete units which are mounted upon each other. The system consists of a **PHILIPP Rebar Pocket** (picture 1) for the upper concrete unit, a **PHILIPP Concrete Pocket** (picture 2) for the lower concrete unit and a steel bolt, e.g. steel rebar dia.20mm, length min. 300mm. The respective holder for rebar pocket and concrete pocket are fixed at the mould with nails or screws. Afterwards the pocket and holder are put on the fixed holders (picture 3). Therewith the holders can be removed during demoulding easily.

Table 1: Dimensions PHILIPP Rebar Pocket Holder (plastic)

Art-No.	dia.d [mm]	h [mm]	PU [pcs.]	Weight [kg/100 pcs.]
72TH	23	30	1000	0.5

Table 2: Dimensions PHILIPP Rebar Pocket (plastic)

Art-No.	dia.D [mm]	H [mm]	PU [pcs.]	Weight [kg/100 pcs.]
72DH	29	180	350	3.3

Table 3: Dimensions PHILIPP Concrete Pocket Holder (plastic)

Art-No.	a [mm]	b [mm]	h ₁ [mm]	PU [pcs.]	Weight [kg/100 pcs.]
72TH	80	52	20	300	1.6

Table 4: Dimensions PHILIPP Concrete Pocket (plastic)

Art-No.	A [mm]	B [mm]	H ₁ [mm]	PU [pcs.]	Weight [kg/100 pcs.]
72DT	87	56	150	170	8.0

Mounting of precast concrete units

For the mounting of precast units the steel bolt must be placed into the rebar pocket. Due to interior ribs in the rebar pocket a falling out of the steel bolt is prevented. The concrete pocket in the lower unit must be filled with grouting mortar before the installation of the upper precast unit (picture 4) in a way that the steel bolt is set into the grouting mortar during installation of the upper concrete unit (picture 5). Through shape and size of the concrete pocket the precast unit can be aligned sufficiently.

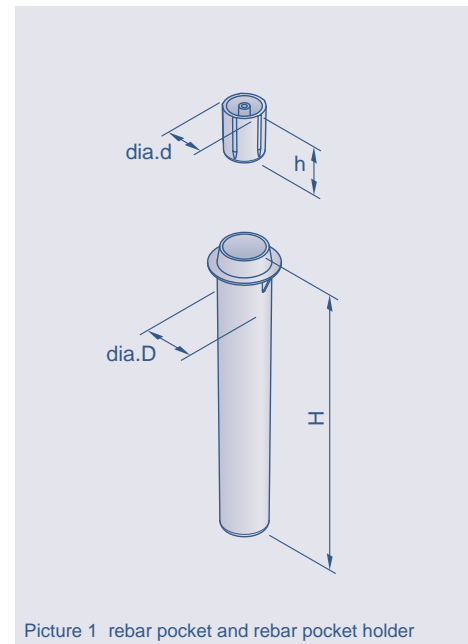

Picture 1 rebar pocket and rebar pocket holder

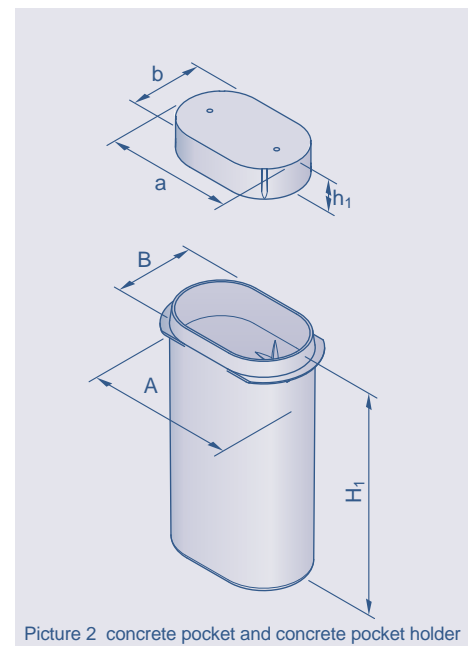

Picture 2 concrete pocket and concrete pocket holder

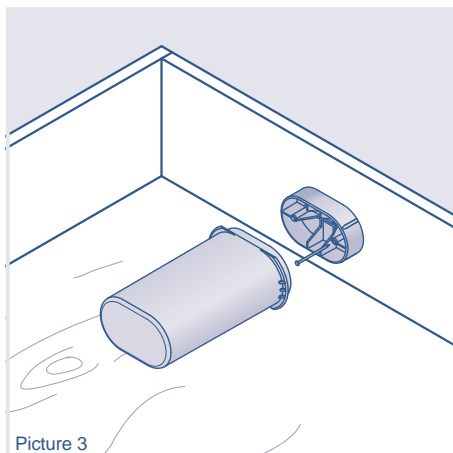

Picture 3

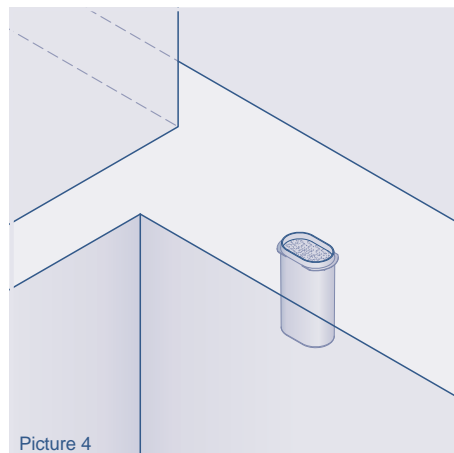

Picture 4

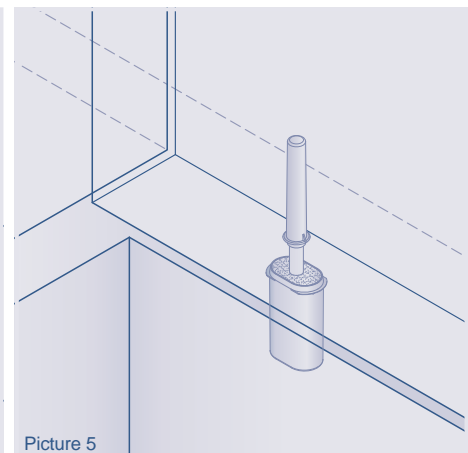

Picture 5